

## ASFA 'S' Worm-Drive Clip

**MIKALOR**

The ASFA 'S' W1 hose clip combines an innovative housing designed to take very high torque and a sturdy 12mm band, which together make this a top-performance hose clip.

The cold-formed stamped band thread, smoothed on the underside, combined with beveled band-edges protects the hose from any damage.

The ASFA 'S' W1 hose clip complies fully with the DIN 3017 norm and also with the RoHS directive EU 20032/95/EC dated 1st July 2006.

This clip is ideally for use in general industrial applications where a robust and competitively priced clip is called for.

The ASFA 'S' W1 is especially recommended for use in agriculture and in fluid transfer applications.

# ASFA 'S' W1 Worm-Drive Clip (9mm bandwidth)

Application Ø		Part n° W1	L max.	s + 0,1 0	h max.	a + 0,3 a - 0,2	b max.	Max. Values* Torque (Nm)	Max. Values* Pressure (Bars)	Box Quantity (MOQ)	Packing
mm	inches										
16-27	5/8-1-1/16	03009001	29,6	0,8	11	12,2	18,8	4,2	45,0	50	400
20-32	25/32-1-1/4	03009002	29,6	0,8	11	12,2	18,8	5,2	45,0	50	400
25-40	1-1-9/16	03009003	29,6	0,8	11	12,2	18,8	5,2	40,0	50	400
30-45	1-3/16-1-3/4	03009004	29,6	0,8	11	12,2	18,8	5,2	35,0	50	400
32-50	1-1/4-1-31/32	03009005	29,6	0,8	11	12,2	18,8	6,0	35,0	50	400
40-60	1-9/16-2-3/8	03009006	29,6	0,8	11	12,2	18,8	6,0	30,0	50	400
50-70	1-31/32-2-3/4	03009007	31,6	0,8	11	12,2	18,8	6,8	25,0	50	400
60-80	2-3/8-3-1/8	03009008	31,6	0,8	11	12,2	18,8	6,8	20,0	50	50
70-90	2-3/4-3-1/2	03009009	31,6	0,8	11	12,2	18,8	6,8	17,0	50	50
80-100	3-1/8-3-15/16	03009010	31,6	0,8	11	12,2	18,8	6,8	14,0	25	200
90-110	3-1/2-4-5/16	03009011	31,6	0,8	11	12,2	18,8	6,8	12,0	25	200
100-120	3-15/16-4-23/32	03009012	31,6	0,8	11	12,2	18,8	6,8	10,0	25	200
110-130	4-5/16-5-1/8	03009013	31,6	0,8	11	12,2	18,8	6,8	8,0	25	25
120-140	4-23/32-5-1/2	03009014	34,6	0,8	11	12,2	18,8	6,8	7,0	25	25
130-150	5-1/8-5-29/32	03009015	34,6	0,8	11	12,2	18,8	6,8	6,0	25	25
140-160	5-1/2-6-5/16	03009016	34,6	0,8	11	12,2	18,8	6,8	5,0	25	25
150-170	5-29/32-6-11/16	03009017	34,6	0,8	11	12,2	18,8	6,8	4,0	25	25
160-180	6-5/16-7-3/32	03009018	34,6	0,8	11	12,2	18,8	6,8	3,0	25	25
170-190	6-11/16-7-15/32	03009019	34,6	0,8	11	12,2	18,8	6,8	2,0	10	10
180-200	7-3/32-7-7/8	03009020	34,6	0,8	11	12,2	18,8	6,8	2,0	10	10
190-210	7-31/64-8-17/64	03009021	34,6	0,8	11	12,2	18,8	6,8	1,8	10	10
200-220	7-7/8-8-21/32	03009022	34,6	0,8	11	12,2	18,8	6,8	1,8	10	10
210-230	8-17/64-9-1/16	03009023	34,6	0,8	11	12,2	18,8	6,8	1,6	10	10
220-240	8-21/32-9-29/64	03009024	34,6	0,8	11	12,2	18,8	6,8	1,6	10	10

**W1 Screw:** Qst 36-3 Mild steel (DIN 1.0213) Silver-white Cr3 Zinc-Plated **Band and Housing:** Galvanized steel S/EN 10292 (DIN 1.0935)

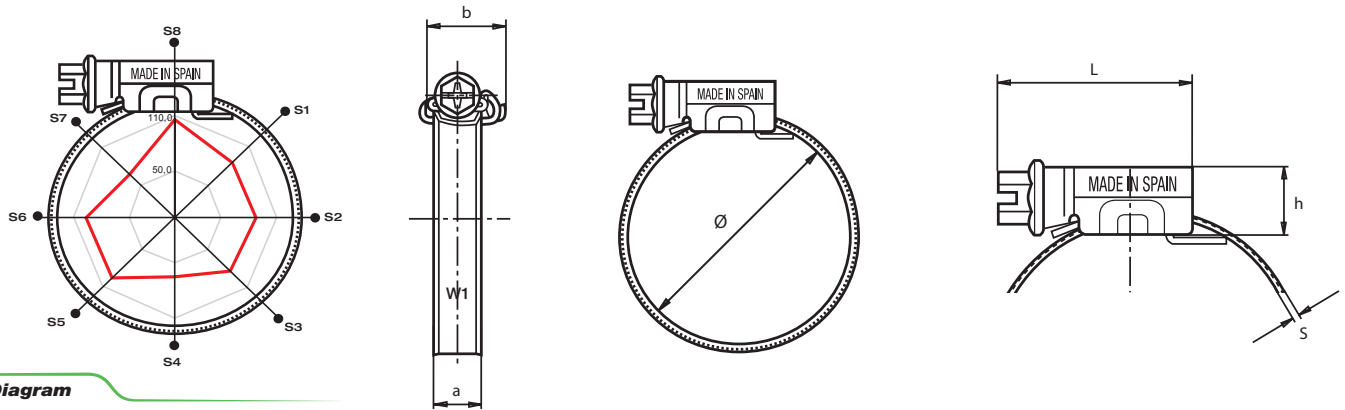

### Polar Diagram

Sectors	S1	S2	S3	S4	S5	S6	S7	S8
5 Nm	86,6	87,2	83,2	64,9	93,9	96,9	67,6	105,4

Torque / Efficiency [ Nm / daN ]

\* The maximum application pressure can vary depending on the type of hose used and the geometry of the coupling. Patented Worldwide.