

# High Pressure Hydraulic Filtration



## MATERIALS

Head and cover: Aluminium alloy  
 Bowl: Polyamide for FRA21-31-32-33-41  
 Zinc plated steel for FRA11-42-51-52-53-5D  
 Bypass valve: Polyamide  
 Seals: NBR Nitrile  
 FKM Fluoroelastomer on request  
 Indicator housing: Brass

## PRESSURE (ISO 10771-1:2002)

Max working: 300 kPa (3 bar)  
 Test: 500 kPa (5 bar)  
 Bursting: 1 MPa (10 bar)  
 Collapse, differential for the filter element (ISO 2941): 300 kPa (3 bar)

## BYPASS VALVE

Setting: 170 kPa (1,7 bar)  $\pm$  10%

## WORKING TEMPERATURE

From -25° to +110° C

## COMPATIBILITY (ISO 2943:1999)

Full with fluids: HH-HL-HM-HV-HTG (according to ISO 6743/4)  
 For fluids different than the above mentioned, please contact our Sales Department.



# Return Filters

## Installation Drawing

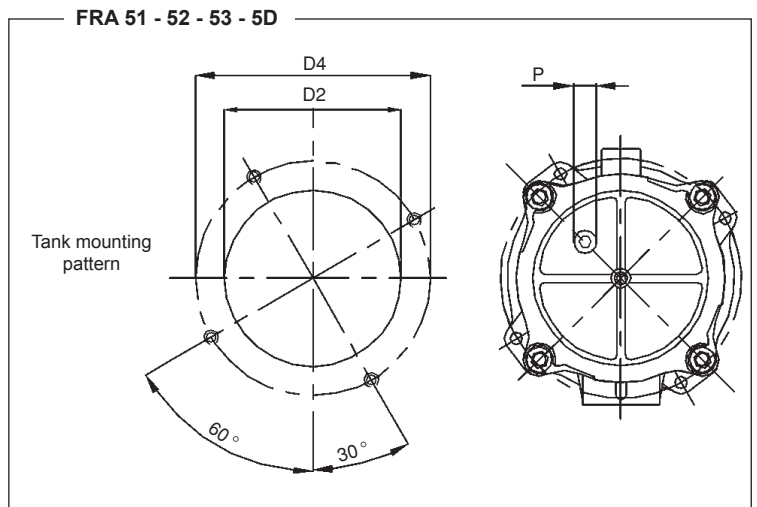
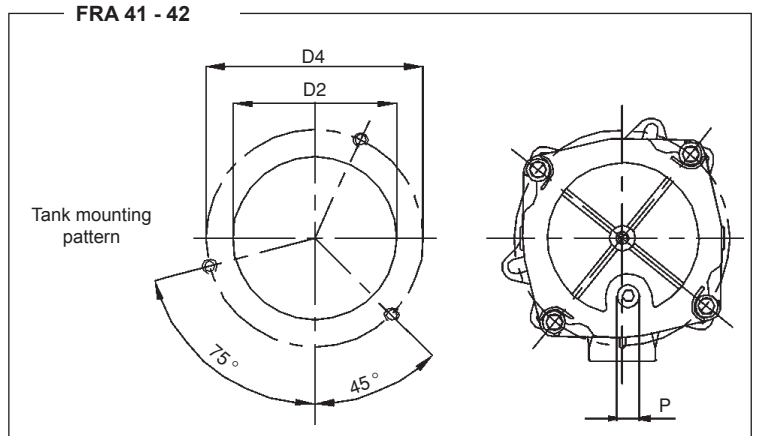
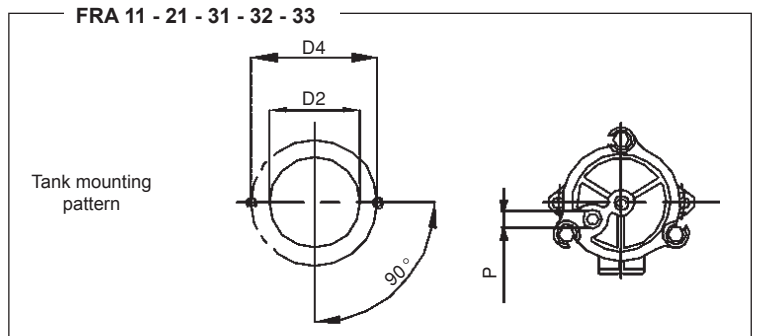
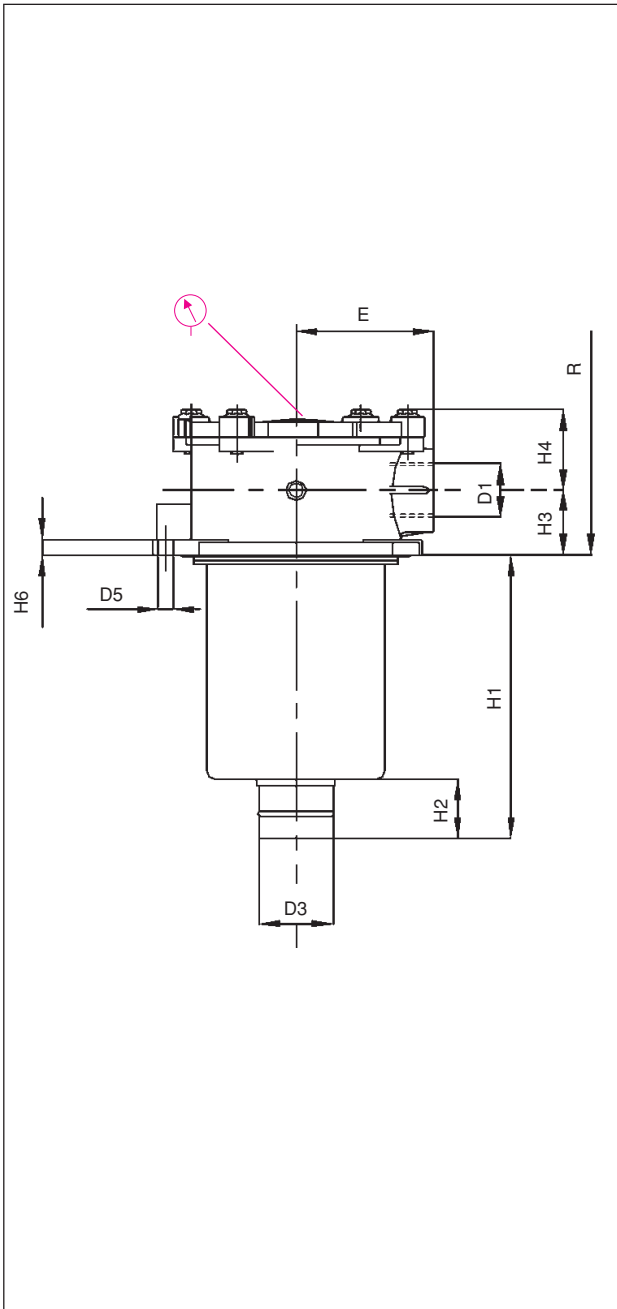

### FILTER HOUSING

	D1	min D2	max D2	D3	D4	D5	E	H1	H2	H3	H4	H6	P	R	kg
FRA11	3/8"	50	50	12	80	6,5	40	59	16	12	33	9	1/8"	90	0,30
FRA21	1/2"	67	68	24	90	6,5	50	80	20	22	33	9	3/8"	120	0,45
FRA31	1/2" - 3/4"	89	90	28	115	9	67	102	25	28	47	10	3/8"	150	0,80
FRA32	3/4" - 1"	89	90	28	115	9	67	150	25	28	47	10	3/8"	190	0,95
FRA33	3/4" - 1"	89	90	40	115	9	67	234	30	28	47	10	3/8"	270	1,10
FRA41	1" - 1 1/4" - 1 1/2"	126	131	40	175	10,5	95	248	50	35	56	13	1/2"	289	2,10
FRA42	1" - 1 1/4" - 1 1/2"	126	131	40	175	10,5	95	265	30	35	56	13	1/2"	306	2,30
FRA51	1 1/4" - 1 1/2" - 2" - 2 1/2"	174	180	50	220	10,5	115	178	50	55	69	13	1/2"	250	3,10
FRA52	1 1/4" - 1 1/2" - 2" - 2 1/2"	174	180	63,5	220	10,5	115	240	50	55	69	13	1/2"	315	3,60
FRA53	2" - 2 1/2"	174	180	63,5	220	10,5	115	285	50	55	69	13	1/2"	355	4,10
FRA5D	2" - 2 1/2"	174	180	63,5	220	10,5	115	300	50	55	69	13	1/2"	370	4,30

# Return Filters

## Ordering and Option Chart

		<b>TYPE</b>													
		F = FILTER COMPLETE													
		B = FILTER HOUSING												<b>ELEMENT</b>	
<b>R</b>	<b>A</b>	<b>FAMILY, NOMINAL SIZE &amp; LENGTH</b>												<b>FAMILY SIZE &amp; LENGTH</b>	
		11	21	31	32	33	41	42	51	52	53	5D	R	A	
		<b>PORT TYPE</b>													
		B = BSP thread													
		N = NPT thread													
		S = SAE thread													
		F = SAE flange 3000 psi													
		<b>PORT SIZE</b>													
		03 = 3/8"													
		04 = 1/2"													
		06 = 3/4"													
		08 = 1"													
		10 = 1" 1/4 (F10 not available)													
		12 = 1" 1/2 (** F12 available for FRA4+ only)													
		16 = 2" (F16 not available)													
		20 = 2" 1/2 (F20 only)												(*) special mounting pattern, pls ask for relevant information	
<b>B</b>	<b>BYPASS VALVE</b>														
		B = 170 kPa (1,7 bar)													
		<b>SEALS</b>												<b>SEALS</b>	
		N = NBR Nitrile												N = NBR	
		F = FKM Fluoroelastomer												F = FKM	
		<b>FILTER MEDIA</b>												<b>FILTER MEDIA</b>	
		FA = fiber 5 μm(e) β>1.000												FA = fiber 5 μm(e)	
		FB = fiber 7 μm(e) β>1.000												FB = fiber 7 μm(e)	
		FC = fiber 12 μm(e) β>1.000												FC = fiber 12 μm(e)	
		FD = fiber 21 μm(e) β>1.000												FD = fiber 21 μm(e)	
		CC = cellulose 10 μm β>2												CC = cellulose 10 μm	
		CD = cellulose 25 μm β>2												CD = cellulose 25 μm	
		ME = wire mesh 60 μm												ME = wiremesh60 μm	
		<b>CLOGGING INDICATOR</b>													
		01=1/8" port, plugged												When the filter is ordered with FKM seals, the first digit of the indicator code is a letter (please see page 184 - 185).	
		30 = press. gauge, rear connection													
		32 = press. gauge, bottom connection													
		P1 = SPDT, press. switch													
		<b>ACCESSORIES</b>													
		W = without													
		P = with filling plug													
<b>X</b>	<b>ACCESSORIES</b>														
		X = no other accessory available													

FILTER ELEMENT						
	A	B	C	kg	Area (cm <sup>2</sup> )	
					Media F+	Media C+
ERA11	38	13	50	0,05	270	345
ERA21	52	24	70	0,10	310	380
ERA31	70	28	85	0,20	620	990
ERA32	70	28	130	0,25	1.000	1.600
ERA33	70	40	210	0,40	1.660	2.670
ERA41	99	40	211	0,75	3.800	4.280
ERA42	99	40	250	0,90	4.550	5.100
ERA51	130	51	140	1,00	4.140	4.360
ERA52	130	63	200	1,35	6.190	6.520
ERA53	130	63	251	1,50	7.930	8.350
ERA5D	130	63	266	1,60	8.400	8.800

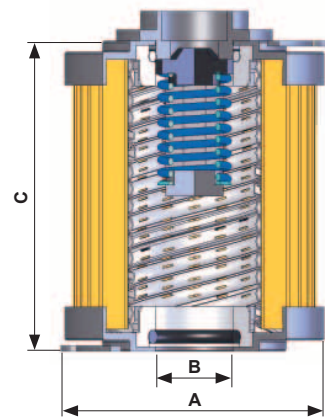

# Return Filters

## FLUID SPEED

(when selecting the filter size, we suggest to consider also the max recommended fluid speed (in return lines normally  $1,5 < v < 4$  m/s))

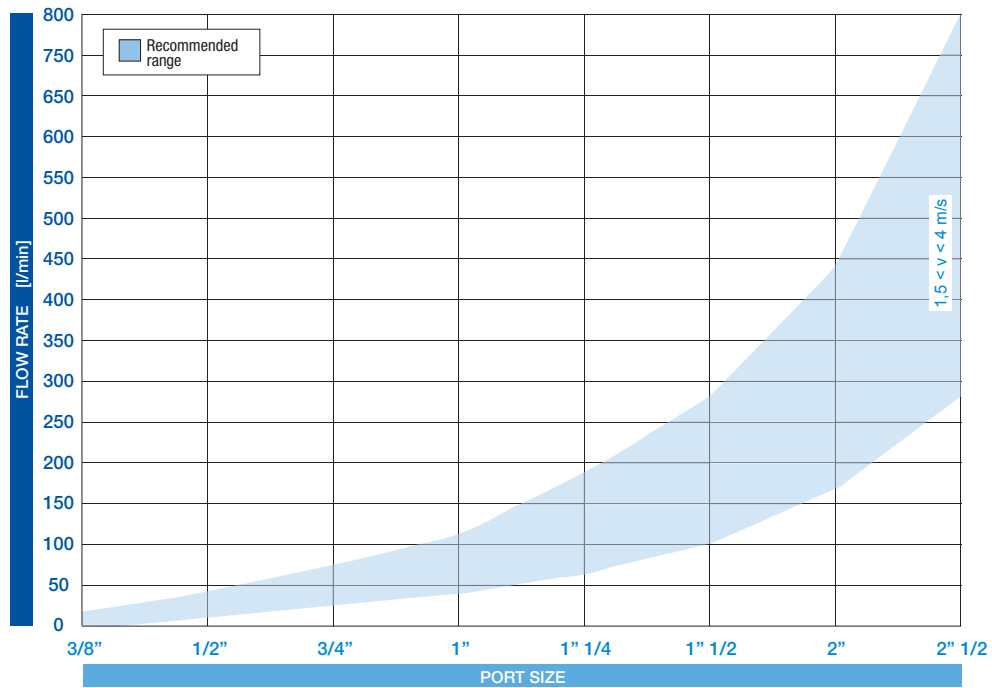

## PRESSURE DROP CURVES ( $\Delta p$ )

The "Assembly Pressure Drop ( $\Delta p$ )" is obtained by adding the pressure drop values of the Filter Housing and of the Clean Filter Element corresponding to the considered Flow Rate and it must be lower than 50 kPa (0,5 bar).

## FILTER HOUSING PRESSURE DROP

(mainly depending on the port size)

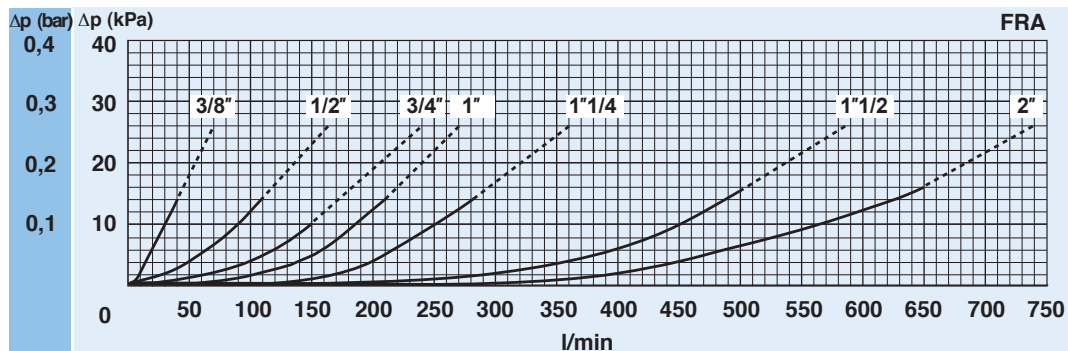

# Return Filters

## CLEAN FILTER ELEMENT PRESSURE DROP WITH F+, C+ AND ME MEDIA (depending both on the internal diameter of the element and on the filter media)

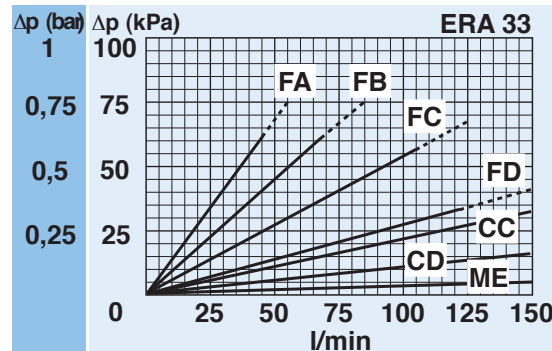
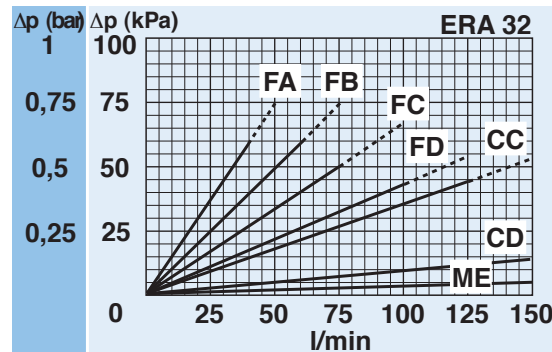
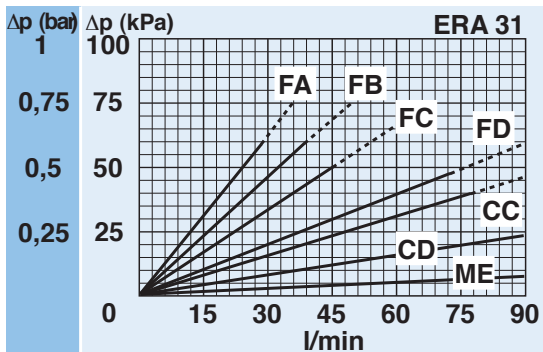
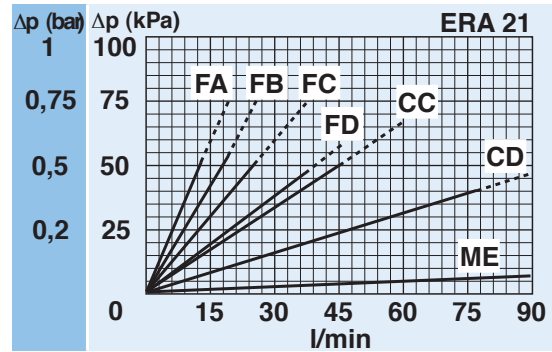
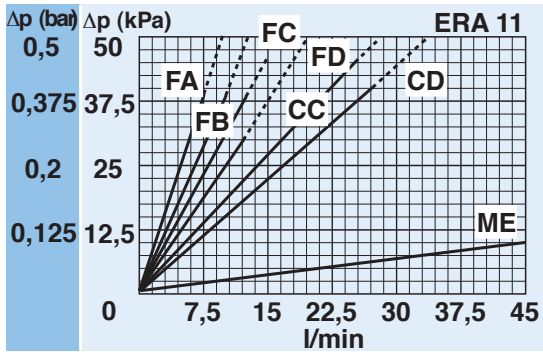

### BYPASS VALVE PRESSURE DROP

When selecting the filter size, these curves must be taken into account if it is foreseen that any flow peak is to be absorbed by the bypass valve, it also must be of proper configuration to avoid pressure peaks. The valve pressure drop is directly proportional to fluid specific gravity.

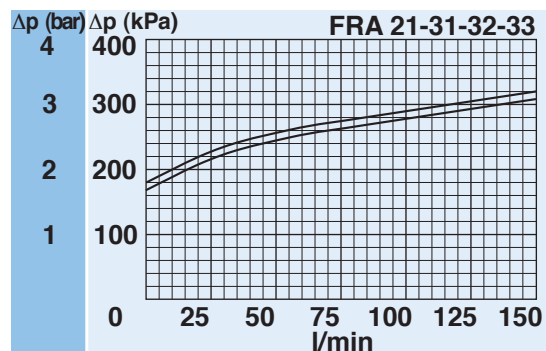

N.B. All the curves have been obtained with mineral oil having a kinematic viscosity 30 cSt and specific gravity 0,9 kg/dm<sup>3</sup>; for fluids with different features, please consider the factors described in the first part of this catalogue. All the curves are obtained from test done at the UFI HYDRAULIC DIVISION Laboratory, according to the specification ISO 3968:2005. In case of discrepancy, please check the contamination level, viscosity and features of the fluid in use.

# Return Filters

## PRESSURE DROP CURVES ( $\Delta p$ )

The “Assembly Pressure Drop ( $\Delta p$ )” is obtained by adding the pressure drop values of the Filter Housing and of the Clean Filter Element corresponding to the considered Flow Rate and it must be lower than 50 kPa (0,5 bar).

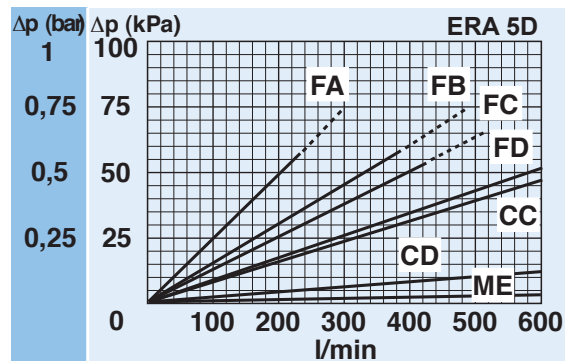
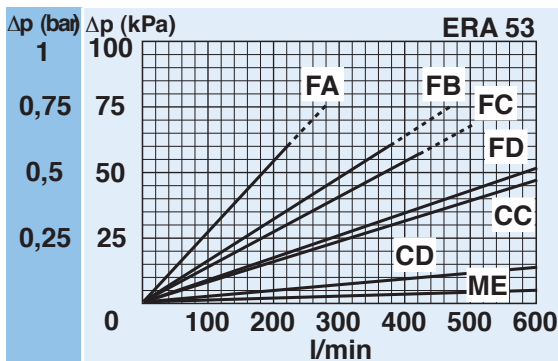
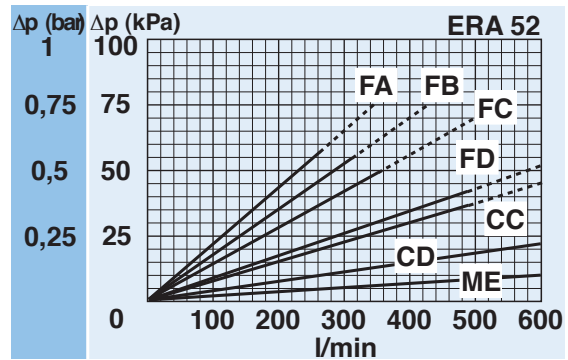
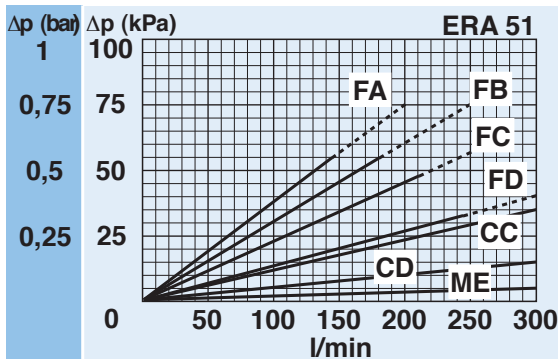
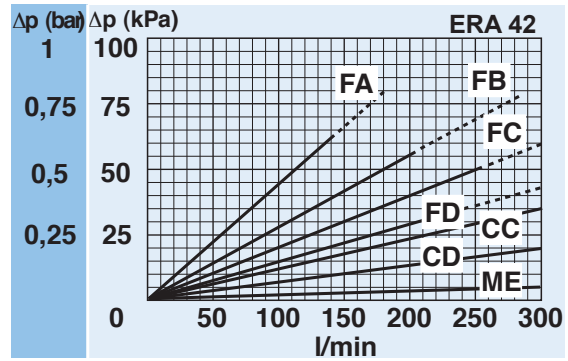
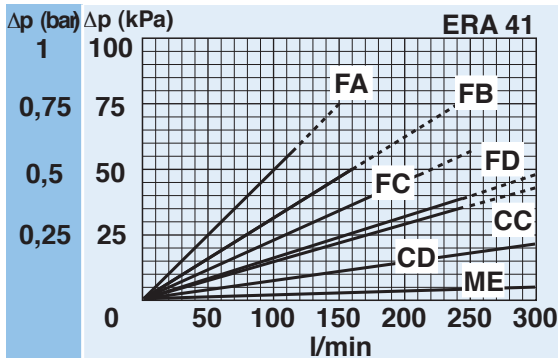

## BYPASS VALVE PRESSURE DROP

When selecting the filter size, these curves must be taken into account if it is foreseen that any flow peak is to be absorbed by the bypass valve, it also must be of proper configuration to avoid pressure peaks. The valve pressure drop is directly proportional to fluid specific gravity.

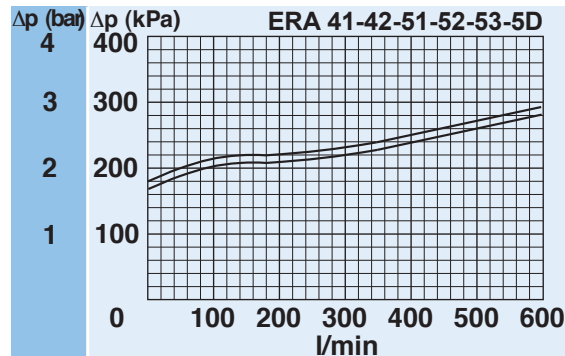

N.B. All the curves have been obtained with mineral oil having a kinematic viscosity 30 cSt and specific gravity 0,9 kg/dm<sup>3</sup>; for fluids with different features, please consider the factors described in the first part of this catalogue. All the curves are obtained from test done at the UFI HYDRAULIC DIVISION Laboratory, according to the specification ISO 3968:2005. In case of discrepancy, please check the contamination level, viscosity and features of the fluid in use.



