

Footmaster Multifunctional Levelling Castors

KGD Light and Medium Duty Castors

Designed to offer 360° swivel castor function, this easily operated range offer mobility, levelling and vibration damping features for light to medium weight equipment. Footmaster multifunctional castors allow users to move and position large equipment single handedly. Levelling can be achieved with ease. Static load capacities of 50kg to 500kg and Dynamic load capacities of 25kg to 250kg offer unrivalled mobility.



KGD-40S

- 50kg Static and 25kg Dynamic load capacity
- Die cast aluminium footpad with vibration damping rubber pad
- Forged steel flange and swivel head
- Die cast aluminium body
- Powder coated ivory finish
- Nylon handwheel with M8 leveler

KGD/R-60F/S

- 250kg Static and 125kg Dynamic load capacity
- Die cast aluminium footpad with vibration damping rubber pad
- Forged steel Top plate, flange and swivel head
- Die cast aluminium body
- Powder coated ivory finish
- Nylon handwheel with M10 leveler

KGD/R-80F/S

- 500kg Static and 250kg Dynamic load capacity
- Die cast aluminium footpad with vibration damping rubber pad
- Forged steel Top plate, flange and swivel head
- Die cast aluminium body
- Powder coated ivory finish
- Nylon handwheel with M12 leveler or retractable ratchet

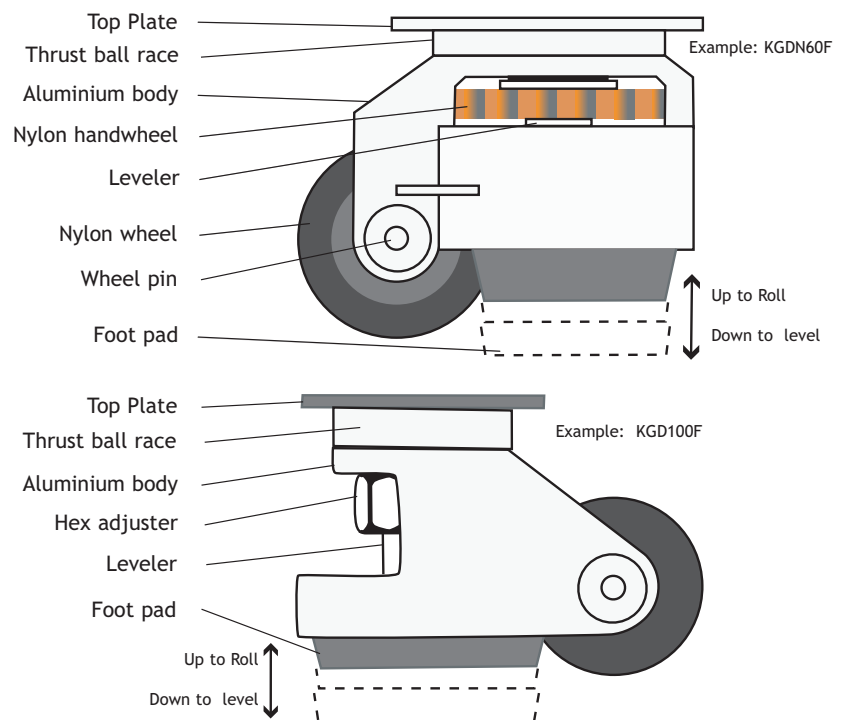

KGD Heavy Duty Castors

Designed for heavy machinery applications, this easily operated range solve problems associated with movement required for positioning and maintenance. Static load capacities of 750kg to 1500kg and Dynamic load capacities of 375kg to 750kg offer unparalleled manouverability and flexibility for large scale equipment.

KGD-100F

- 750kg Static and 375kg Dynamic load capacity
- Die cast aluminium footpad with vibration damping rubber pad
- Forged steel Top plate, flange and swivel head
- Die cast aluminium body
- Powder coated ivory finish
- Nylon handwheel with M12 leveler

KGD-150F

- 1500kg Static and 750kg Dynamic load capacity
- Die cast aluminium footpad with vibration damping rubber pad
- Forged steel Top plate and swivel head
- Die cast aluminium body
- Powder coated ivory finish
- Hex adjuster with M20 leveler (spanner required)

KGD-120F

- 1000kg Static and 500kg Dynamic load capacity
- Die cast aluminium footpad
- Forged steel Top plate and swivel head
- Die cast aluminium body
- Powder coated ivory finish
- Hex adjuster with M16 leveler (spanner required)

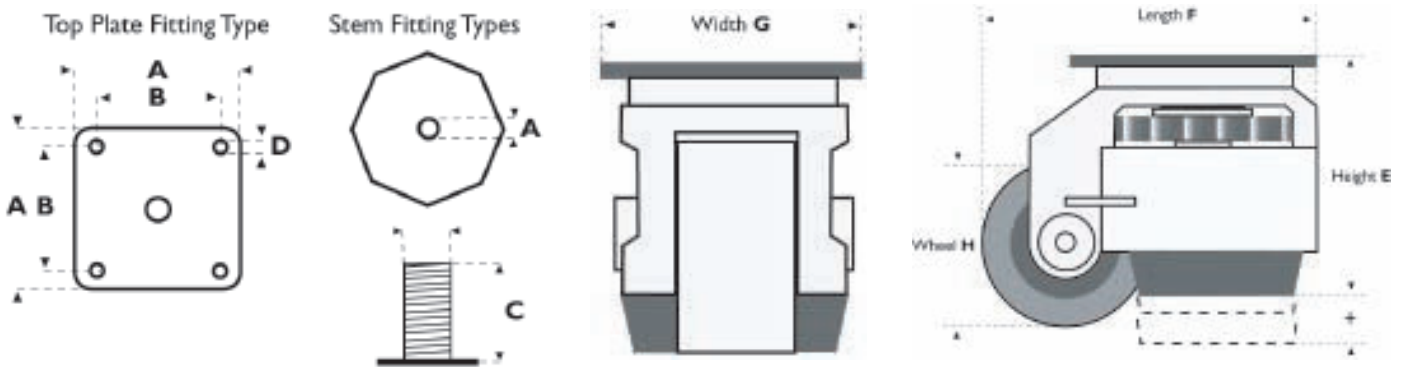

Fitting Type	Load Cap. (kg)		Method of Operating	Top Plate (mm) A	Fixing Centres (mm) B	Stem Size (mm) C	Bolt Holes (mm) D	Dimensions (mm)				Unit Weight (kg)	Catalogue Reference
	Static	Dynamic						E	F	G	H		
Stem	50	25	Handwheel	O 40AF	-	M8 x 15	-	71 + 10	84	58	42	0.35	KGD-40S
Top Plate	250	125	Handwheel	73 x 73	58 x 58	-	6.5	82 + 10	100	70	50	0.75	KGD-60F
Stem	250	125	Handwheel	O 46AF	-	M12 x 18	-	82 + 10	100	70	50	0.75	KGD-60S
Top Plate	250	125	Ratchet	73 x 73	58 x 58	-	6.5	82 + 10	100	70	50	0.75	KGDR-60F
Stem	250	125	Ratchet	O 46AF	-	M12 x 18	-	82 + 10	100	70	50	0.75	KGDR-60S
Top Plate	500	250	Handwheel	90 x 90	70 x 70	-	9	102 + 15	125	85	63	1.35	KGD-80F
Top Plate	500	250	Ratchet	90 x 90	70 x 70	-	9	102 + 15	125	85	63	1.35	KGDR-80F
Top Plate	750	375	Handwheel	95 x 95	70 x 70	-	11	120 + 12	142	95	75	1.85	KGD-100F
Stem	750	375	Handwheel	O 64AF	-	M16 x 24	-	120 + 12	142	95	75	1.85	KGD-100S
Top Plate	1000	500	Hex Spanner	95 x 95	70 x 70	-	11	120 + 12	137	95	75	2.10	KGD-120F
Top Plate	1500	750	Hex Spanner	100 x 100	70 x 70	-	13	130 + 15	137	110	97	3.30	KGD-150F