

Professional Range Mark 2

Filter+Regulator+Lubricator



Specification:

Type	FM2-20-01-C	FM2-30-02-C	FM2-40-03-C FM2-40-04-C	FM2-50-06-C FM2-50-10-C
Port size G	1/8" · 1/4"	1/4" · 3/8"	3/8" · 1/2"	3/4" · 1"
Gauge thread G	1/8"		1/4"	
Fluid	Air			
Operating pressure range MPa	0.15-0.85			
Max.Flow rate L/min	5000	2000	4000	5000
Ambient temperature °C	-10-60			
Filter precision	Standard: 20 μ m			
Oil recommended	ISO VG32			
Cup material	Polycarbonate			
Structure	Overflow type			
Optional	Guard cup	-	●	●
	Bracket	20T	30T	40T

Notes 1: The guard cup of AC200A series can be optional. 2: The cups of AC200A, AC300A series can be optional

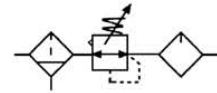

Inner structure drawing:

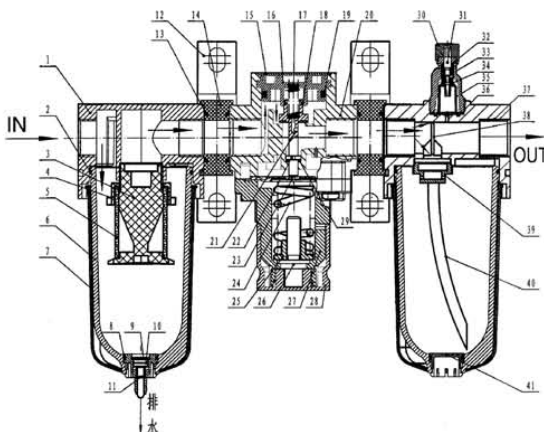

No	code	No	code	No	code
1	filter body	15	panel	29	O -ring
2	O-ring	16	pedestal	30	doom button
3	baffle body	17	regulator core spring	31	adjust pin
4	impeller	18	O -ring	32	O -ring
5	cartridge	19	O -ring	33	middle doom
6	oil cup	20	regulator body	34	O -ring
7	guard cup	21	regulator core	35	doom inner cover
8	O -ring	22	regulator core washer	36	seals
9	circlip	23	diaphragm	37	lubricator body
10	drain nozzle	24	regulator spring	38	damping fin
11	drain spring	25	nut	39	bolt
12	bracket	26	screw	40	oil tube
13	O -ring	27	regulator cover	41	oil cup block
14	connecting block	28	knob		

Dimension(mm):

FM2-30-02-C

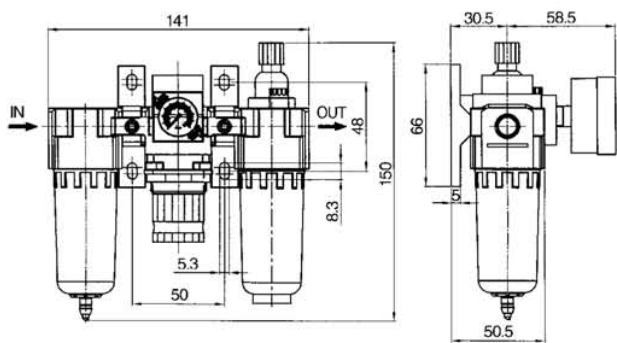

FM2-30-02-C

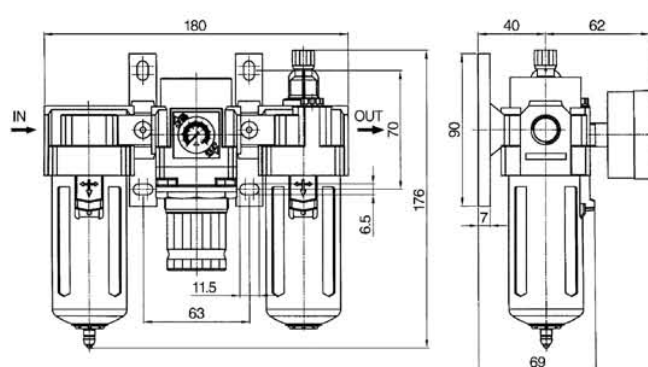

FM2-40-03-C & FM2-40-04-C

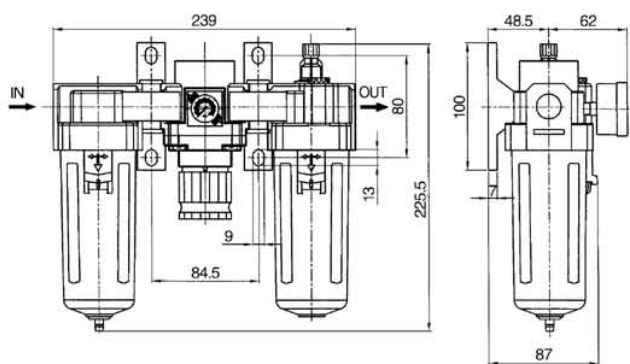

FM2-50-06-C & FM2-50-10-C

