



Air Oil Coolers

The LDC air oil cooler with 24V DC motor is optimised for use in the mobile industry. Together with a wide range of accessories, the LDC cooler is suitable for installation in most applications and environments.

The maximum cooling capacity is 30kW at +ETD 40°C.
Also available with a 12V DC motor.



Maximum Working Temperature:
+120°C



Maximum Static Working Pressure:
21 bar

Maximum Dynamic Working Pressure:
14 bar



LDC Range (In-line Coolers)

LDC-1	LDC-004-B-0-00-000-0-0
LDC-2	LDC-007-B-0-00-000-0-0
LDC-3	LDC-011-B-0-00-000-0-0
LDC-4	LDC-016-B-0-00-000-0-0
LDC-5	LDC-023-B-0-00-000-0-0
LDC-6	LDC-033-B-0-00-000-0-0





The Olaer Group is part of Parker Hannifin since July 1st, 2012. With manufacturing and sales in 14 countries in North America, Asia and Europe, the Olaer Group expands Parker's presence in geographic growth areas and offers expertise in hydraulic accumulator and cooling systems for target growth markets such as oil and gas, power generation and renewable energy.

LDC Air Oil Coolers

For mobile use - maximum cooling capacity 30 kW

The LDC air oil cooler with 12 or 24 V DC motor is optimized for use in the mobile industry. Together with a wide range of accessories, the LDC cooler is suitable for installation in most applications and environments. The maximum cooling capacity is 30 kW at ETD 40°C. Choosing the right cooler requires precise system sizing. The most reliable way to size is with the aid of our calculation program. This program, together with precise evaluations from our experienced, skilled engineers, gives you the opportunity for more cooling per € invested.

Overheating - an expensive problem

An under-sized cooling capacity produces a temperature balance that is too high. The

consequences are poor lubricating properties, internal leakage, a higher risk of cavitation, damaged components, etc. Overheating leads to a significant drop in cost-efficiency and environmental consideration.

Temperature optimisation - a basic prerequisite for cost-efficient operation

Temperature balance in a hydraulic system occurs when the cooler can cool down the energy input that the system does not consume - the system's lost energy ($P_{loss} = P_{cool} = P_{in} - P_{used}$). Temperature optimisation means that temperature balance occurs at the system's ideal working temperature - the temperature at which the oil's viscosity and the air content

comply with recommended values.

The correct working temperature produces a number of economic and environmental benefits:

- The hydraulic system's useful life is extended.
- The oil's useful life is extended.
- The hydraulic system's availability increases - more operating time and fewer shutdowns.
- Service and repair costs are reduced.
- High efficiency level maintained in continuous operation - the system's efficiency falls if the temperature exceeds the ideal working temperature.

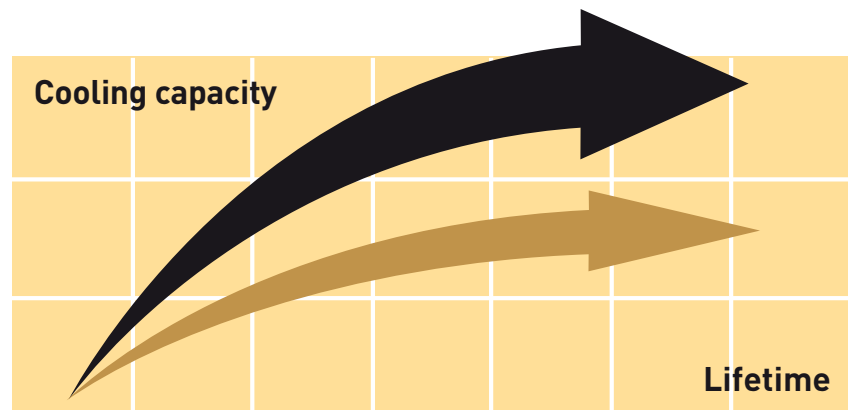

Clever design and the right choice of materials and components produce a long useful life, high availability and low service and maintenance costs.

Compact design and low pressure drop and high cooling capacity.

Easy to maintain and easy to retrofit in many applications.



DC motor 12V/24V

Quiet fan and fan motor.

Compact design and low weight.



Smart DC Drive speed regulation

Smart DC Drive

Smart DC Drive for soft start of fan, as well as lower power consumption and sound level by

means of temperature-controlled speed regulation. Smart DC Drive also eliminates voltage

peaks, thus contributing towards a longer useful life for the fan motor.

Calculate the Cooling Capacity Requirement

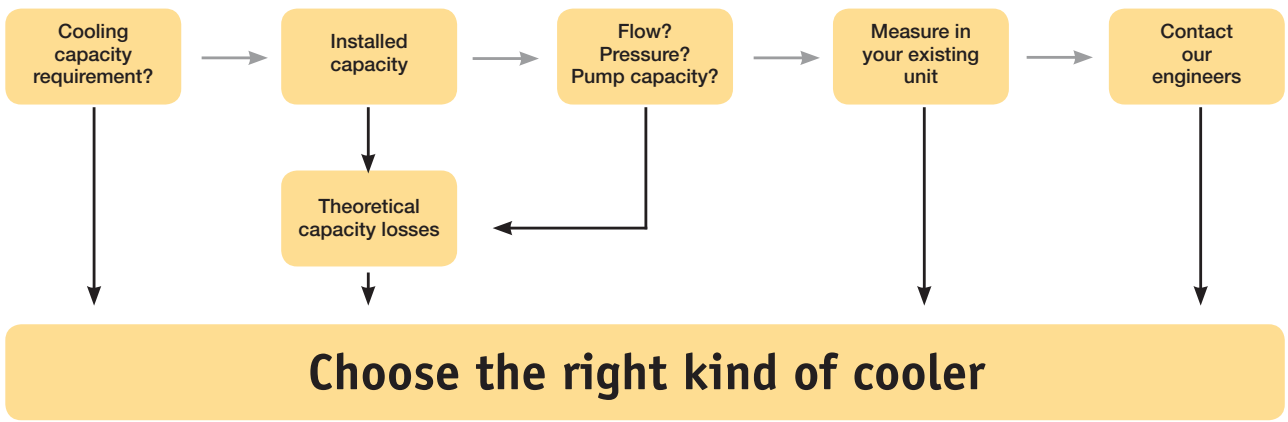

Enter your values

The software interface displays various input fields for parameters such as flow rate, pressure, and pump capacity. A suggested solution is shown for the LAC2 011-4-D cooler, including a technical drawing with dimensions and a photograph of the physical unit.

... suggested solution





Better energy consumption means not only less environmental impact, but also reduces operating costs, i.e. more cooling per € invested.

More Cooling per €

with precise calculations and our engineers' support

Optimal sizing produces efficient cooling. Correct sizing requires knowledge and experience. Our calculation program, combined with our engineers' support, gives you access to this very knowledge and experience. The result is more cooling per € invested. The user-friendly calculation program can be downloaded from www.olaer.se

Valuable system review into the bargain

A more wide-ranging review of

the hydraulic system is often a natural element of cooling calculations. Other potential system improvements can then be discussed – e.g. filtering, offline or online cooling, etc. Contact us for further guidance and information.

Parker Hannifin's quality and performance guarantee insurance for your operations and systems

A constant striving towards more cost-efficient and environment friendly hydraulic systems

requires continuous development. Areas where we are continuously seeking to improve performance include cooling capacity, noise level, pressure drop and fatigue. Meticulous quality and performance tests are conducted in our laboratory. All tests and measurements take place in accordance with standardised methods - cooling capacity in accordance with EN1048, noise level ISO 3743, pressure drop EN 1048 and fatigue ISO 10771-1.



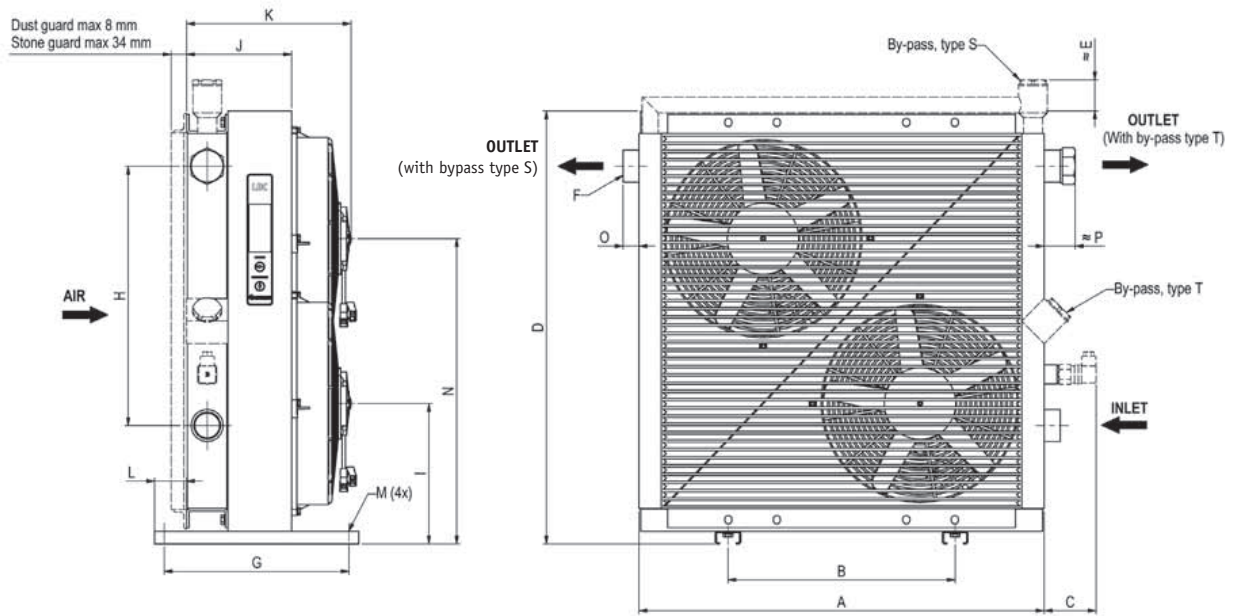

TYPE	A	B	C	D	E	F	G	H	I	J	K	L	Mø	N	O	P	Weight kg (approx)	Acoustic Pressure LpA dB(A)1m*
LDC 002	184	74	72	189	73	G½	190	72	97	105	157	39	9	-	11	25	4	66
LDC 003	244	134	82	227	69	G1	148	90	116	115	157	31	9x14	-	23	35	5	68
LDC 004	267	134	82	256	69	G1	148	90	131	115	162	31	9x14	-	23	35	6	68
LDC 007	330	203	82	345	54	G1	267	160	175	115	178	59	9	-	23	44	9	71
LDC 011	400	360	82	396	65	G1	101	230	200	125	218	-	9x29	-	23	44	12	74
LDC 016	464	416	82	466	63	G1	101	300	235	125	218	-	9x29	-	23	44	15	74
LDC 020	510	470	82	510	61	G1	101	280	257	125	211	-	9x29	-	23	44	18	77
LDC 023	615	356	46	635	26	G1	290	305	200	125	218	50	13	455	-	8	25	77
LDC 033	635	356	82	678	59	G1¼	290	406	220	165	258	50	13	478	25	49	30	77

* = Noise level tolerance ± 3 dB(A)

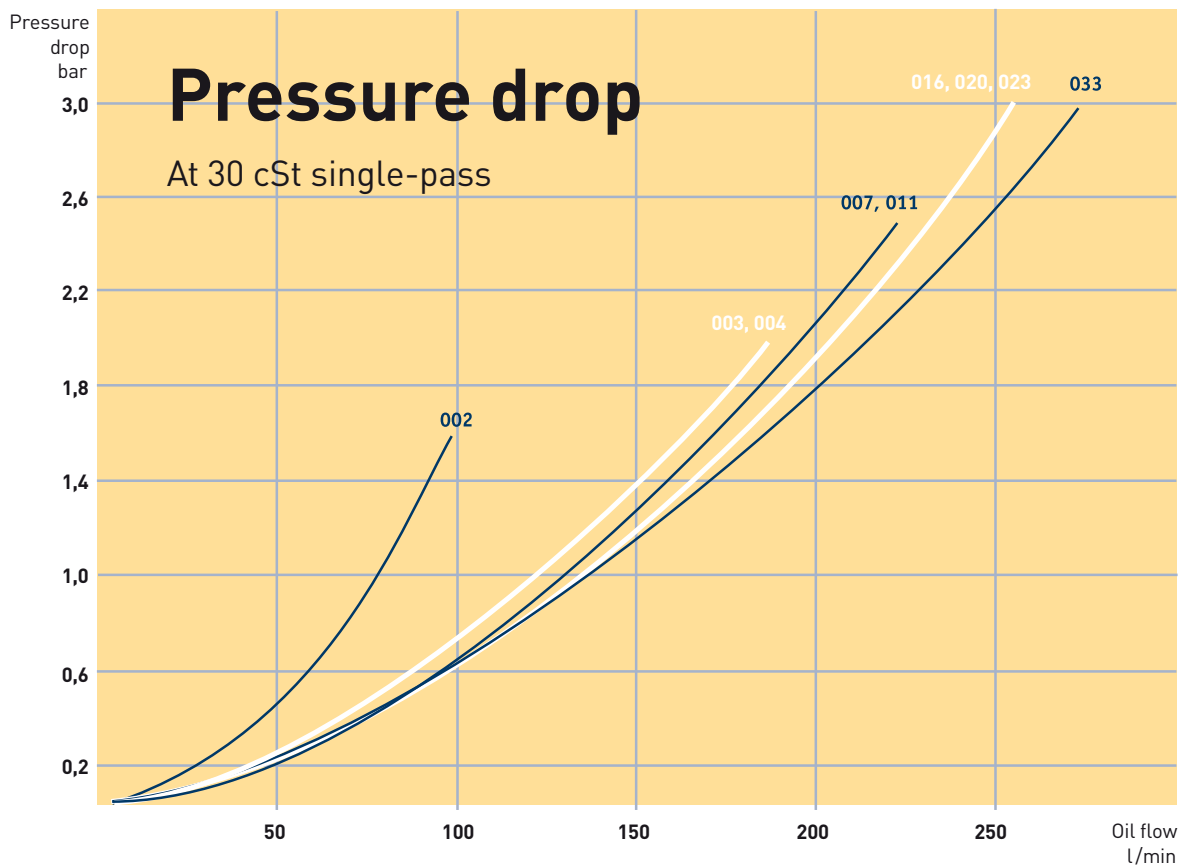
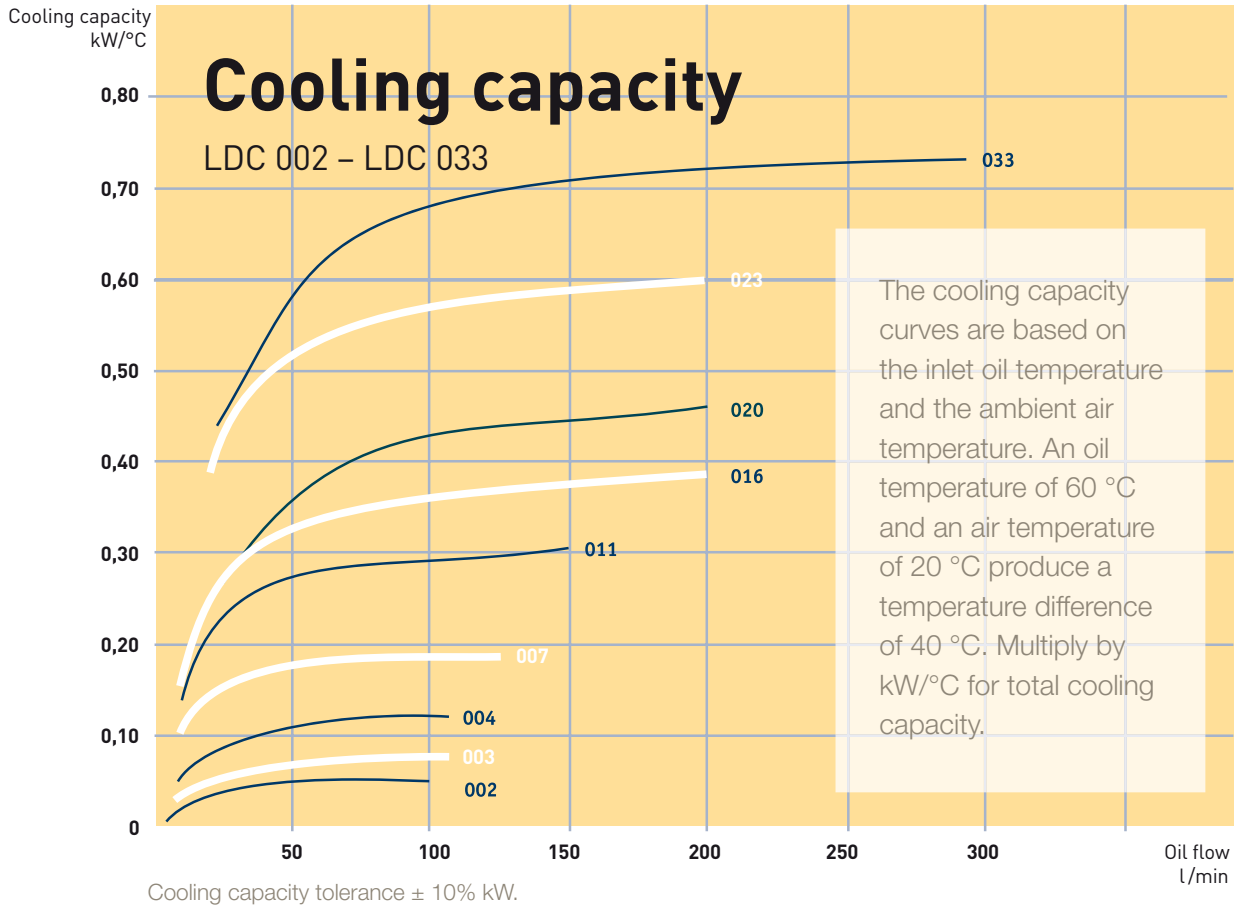

Key for LDC Air Oil Coolers

All positions must be filled in when ordering

EXAMPLE: LDC - 016 - A - S - 00 - S20 - S - 0
 1 2 3 4 5 6 7 8

1. AIR OIL COOLER WITH DC MOTOR = LDC

70 °C, 2.2 bar = T27
 90 °C, 2.2 bar = T29
 * = not for LDC 002 - LDC 004

2. COOLER SIZE

002, 003, 004, 007, 011, 016, 020, 023, 033

3. MOTOR VOLTAGE

12 V = A
 24 V = B

4. Accessories for DC Motor

No motor accessories = 0
 Smart DC Drive, soft start. Requires a thermo contact pos.5 = S

5. THERMO CONTACT

No thermo contact = 00
Thermo contact Smart DC Drive
 40 °C = 40 45 °C = 40
 50 °C = 50 50 °C = 50
 60 °C = 60 55 °C = 55
 70 °C = 70 60 °C = 60
 80 °C = 80 75 °C = 75
 90 °C = 90 95 °C = 95

6. COOLER MATRIX

Standard = 000
 Two-pass = T00
Built-in, pressure-controlled bypass, single-pass
 2 bar = S20
 5 bar = S50
 8 bar = S80
Built-in, pressure-controlled bypass, two-pass*
 2 bar = T20
 5 bar = T50
 8 bar = T80
Built-in temperature and pressure-controlled bypass, single-pass
 50 °C, 2.2 bar = S25
 60 °C, 2.2 bar = S26
 70 °C, 2.2 bar = S27
 90 °C, 2.2 bar = S29
Built-in temperature and pressure-controlled bypass, two-pass*
 50 °C, 2.2 bar = T25
 60 °C, 2.2 bar = T26

7. MATRIX GUARD

No guard = 0
 Stone guard = S
 Dust guard = D
 Dust and stone guard = P

8. STANDARD/SPECIAL

Standard = O
 Special = Z

TECHNICAL SPECIFICATION

FLUID COMBINATIONS

Mineral oil HL/HLP in accordance with DIN 51524
 Oil/water emulsion HFA, HFB in accordance with CETOP RP 77H
 Water glycol HFC in accordance with CETOP RP 77H
 Phosphate ester HFD-R in accordance with CETOP RP 77H

MATERIAL

Cooler matrix Aluminum
 Fan blades/guard Glass fibre reinforced polypropylene
 Fan housing Steel
 Other parts Steel
 Surface treatment Electrostatically powder-coated

COOLER MATRIX

Maximum static working pressure 21 bar
 Dynamic working pressure 14 bar*
 Maximum oil inlet temperature 120 °C

* Tested in accordance with ISO/DIS 10771-1

ELECTRIC MOTOR

COOLING CAPACITY CURVES

The cooling capacity curves in this technical data sheet are based on tests in accordance with EN 1048 and have been produced using oil type ISO VG 46 at 60 °C.

CONTACT PARKER HANNIFIN FOR ADVICE ON

Oil temperatures > 120 °C
 Oil viscosity > 100 cSt
 Aggressive environments
 Ambient air rich in particles
 High-altitude locations

CONNECTION CHART

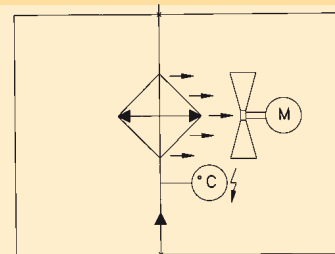

Connection chart for LDC air oil cooler.

LDC	002	003	004	007-020	023-033
Speed (rpm)	3 700	3 670	3 350	3 060	3 060
Protection std.	IP 68	IP 68	IP 68	IP 68	IP 68
Insulation class	H	H	H	H	H
Ambient temp.	-30°C - +80°C				
Power consump. (A) 12 V	6.5	8	8	20	2x20*
Power consump. (A) 24 V	3.5	4	4	10	2x10*

* = LDC 023 and LDC 033 uses two motors

The information in this brochure is subject to change without prior notice.



HosesDirect

www.hoses.co.uk

8
 www.hoses.co.uk