

Pressure Reducing Valves Europress



ITAP SpA, founded in Lumezzane (Brescia) in 1972, is currently one of the leading production companies in Italy of valves, fittings and distribution manifolds for plumbing and heating systems. Thanks to fully automated production processes, with 63 tooling machines and 25 assembly lines, we are able to produce 150,000 pieces per day. Our innate pursuit for innovation and observance of technical regulations in force is supported by the company certification ISO 9001: 2008. The company has always considered its focus on quality as the main tool to obtaining significant business results: today ITAP SpA is proud to offer products bearing the approval of numerous international certifying bodies.

Europress pressure reducing valve is a device which reduces and stabilizes the upstream pressure to an adjusted downstream pressure. When the entering pressure from the public mains is too high and variable, pressure reducing valve stabilizes the downstream pressure to the adjusted one. Possible variations of the upstream pressure do not influence the adjusted downstream pressure. This range of pressure reducing valves allows the operator to adjust the downstream pressure to a set figure.

Pressure reducing valves are suitable for domestic water services, heating and air-conditioning plants, compressed air systems*. They can be used with water, compressed air and non-aggressive fluids. ITAP Pressure reducing valves comply with the requirements of Council Directive 97/23/EC (PED) and the CE marking is not requested according to art. 3 clause 3 of DL 25/02/2000 n. 93.

(* In the type-testing according to PED Council Directive, it is necessary that pressure reducing valves were approved as a part of the installation).

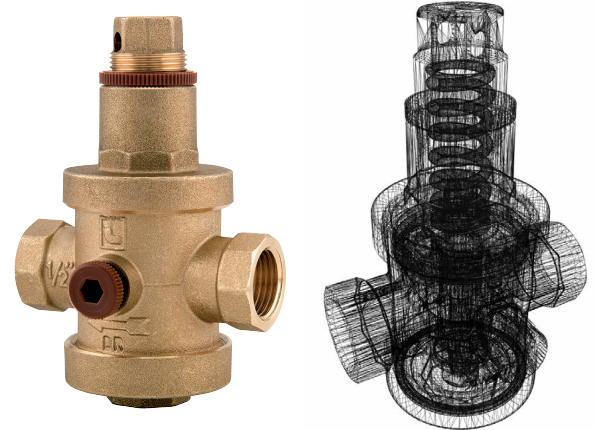

Pressure Reducing Valves Europress



Compensated piston operation.

Female/female threads.

Body in dezincification resistant brass.

Minimum and maximum working temperatures: 0°C, 80°C.

Maximum inlet pressure: 25bar.

Outlet pressure can be adjusted:

- 1/2" - 3/4" - 1" between 1 and 5,5 bar.

- 1"1/4 through 4" between 1 and 6 bar.

Factory preadjustment 3,5 bar.

Outlet pressure gauge connection 1/4" on both sides.

Threads ISO228 (equivalent to DIN EN ISO 228 and BS EN ISO 228).



SIZE	PRESSURE	CODE	PACKING
1/2" (DN 15)	25bar/362,5psi	IT243-12	1/34
3/4" (DN 20)	25bar/362,5psi	IT243-34	1/34
1" (DN 25)	25bar/362,5psi	IT243-1	1/18
1"1/4 (DN 32)	25bar/362,5psi	IT243-114	1/9
1"1/2 (DN 40)	25bar/362,5psi	IT243-112	1/9
2" (DN 50)	25bar/362,5psi	IT243-2	1/8

Overall Dimensions

	1/2"	3/4"	1"	1"1/4	1"1/2	2"
DN	15	20	25	32	40	50
A	77	85	91	118	126	142
B	125,5	125,5	159	218	225	250
C	40	40	59	69,5	126	87
F	12	12	13	18	18	20
Kg/cm2 bar	25	25	25	25	25	25
LBS - psi	362,5	362,5	362,5	362,5	362,5	362,5

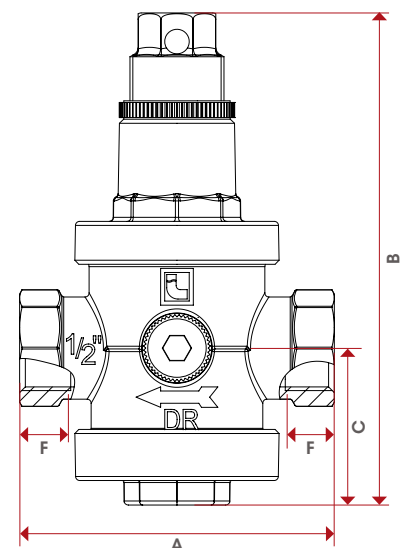

Materials from 1/2" to 1"

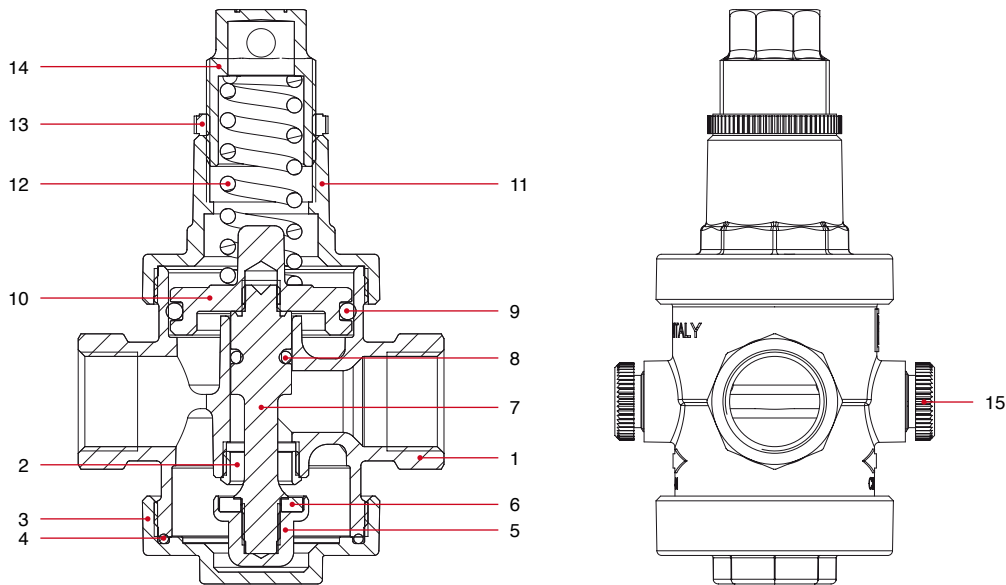

POS.	DESCRIPTION	N.	MATERIAL
1	Body	1	Dezincification resistant brass CW625N
2	Seat	1	Stainless steel AISI 303
3	Bottom plug	1	Dezincification resistant brass CW625N
4	O-Ring	1	EPDM
5	Shutter	1	Dezincification resistant brass CW625N
6	Flat seat washer	1	EPDM
7	Seat	1	Dezincification resistant brass CW625N
8	O-Ring	1	EPDM
9	O-Ring	1	EPDM
10	Diaphragm	1	Dezincification resistant brass CW625N
11	Upper plug	1	Brass CW617N
12	Spring	1	EN 10270-1 DH
13	Nut	1	Nylon
14	Regulator	1	Brass CW617N
15	Cap	1	POM

Materials from 1"1/4 to 2"

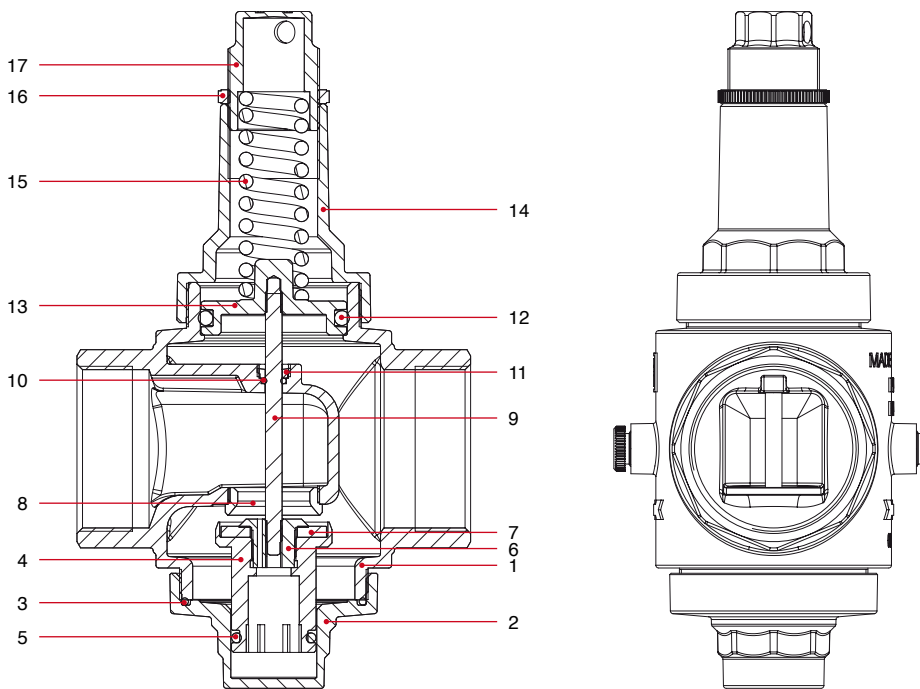

POS.	DESCRIPTION	N.	MATERIAL
1	Body	1	Dezincification resistant brass CC770S
2	Bottom plug	1	Dezincification resistant brass CW625N
3	O-Ring	1	NBR
4	Shutter	1	Dezincification resistant brass CW625N
5	O-Ring	1	NBR
6	Stop washer	1	Dezincification resistant brass CW625N
7	Flat seat washer	1	NBR
8	Seat	1	Stainless steel AISI 303
9	Stem	1	Stainless steel AISI 303
10	O-Ring	1	NBR
11	Stop ring	1	Dezincification resistant brass CW625N
12	O-Ring	1	NBR
13	Diaphragm	1	Dezincification resistant brass CW625N
14	Upper plug	1	Brass CW617N
15	Spring	1	EN 10270-1 SM/SH
16	Nut	1	Nylon
17	Regulator	1	Brass CW617N
18	Cap	2	POM

Pressure Drop Chart with Water

Pressure drop diagram includes the loss of pressure proportional to a specific flow rate. According to the requested flow rate, it is possible to measure the water system and the pressure reducing valve correctly (it would be better to have a flow speed between 1 m/s and 2 m/s in the piping).

INSTANCE:

In case of 1/2" pressure reducing valve with an adjusted downstream pressure of 3,5 bar and a flow rate of 35 l/min, the pressure drop diagram states a loss of pressure of 0.62 bar. It means that the pressure gauge installed on the outlet way of pressure reducing valve shows a figure of 2.38 bar (= 3,5 bar – 0.62 bar).

Here mentioned figures refer to: upstream pressure 8 bar, downstream pressure 3,5 bar.

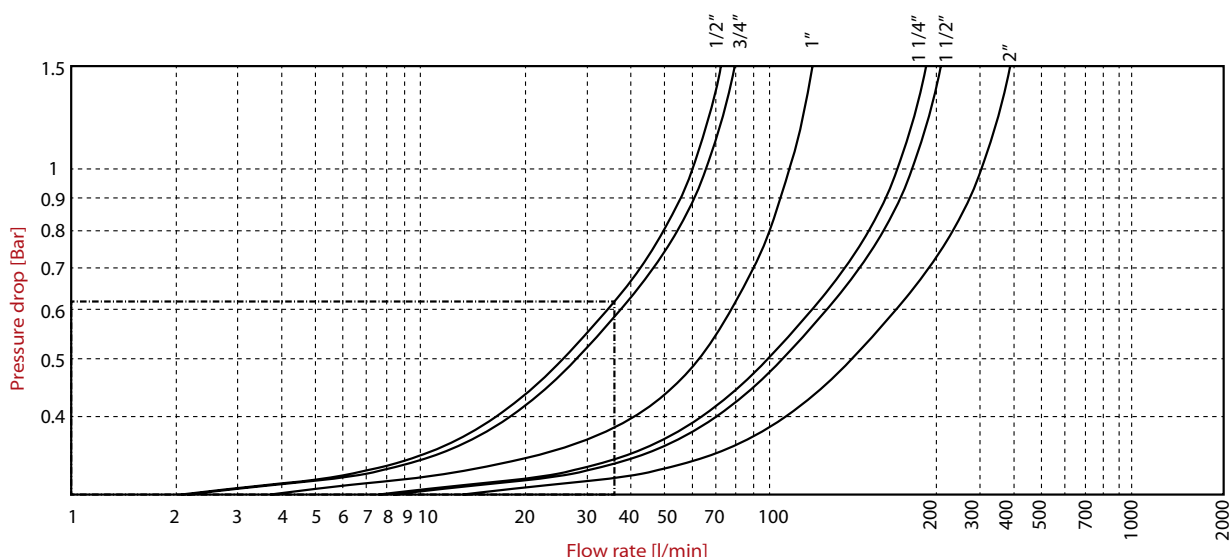

DN	1/2"	3/4"	1"	1 1/4"	1 1/2"	2"
Kv (m3/h)	3,6	4	6,6	9,6	10,2	18

Manufacturers Instructions

Installation

For the best use and duration of the system, it is necessary to comply with the following instructions on installation, with the national regulations and with relevant local requirements.

- Place of installation has to be protected from frost and has to be easily inspectable
- Install the pressure reducing valve on the private water system, immediately downstream of the water meter
- It would be better to install shut-off valves upstream and downstream of the pressure reducing valve, to facilitate the maintenance operations
- In order to protect pressure reducing valve from overpressure, install a check valve immediately downstream of the pressure reducing valve
- The right scheme of installation is shown in Fig. 5.2
- In case of water heater downstream of the pressure reducing valve, install an expansion vessel between the valve and the water heater
- In order to avoid cavitation and therefore excessive noisiness, it is strongly recommended that the ratio between maximum upstream pressure and regulating downstream pressure does not exceed the value of 2,5.
- Pressure reducing valve is not a safety device. It would be better to install all the necessary safety relief valves.

Please, duly note the downstream pressure of the reducing valve has not to be higher than the maximum working pressure of the devices installed in the private water system, in order to avoid possible damages or malfunctions.

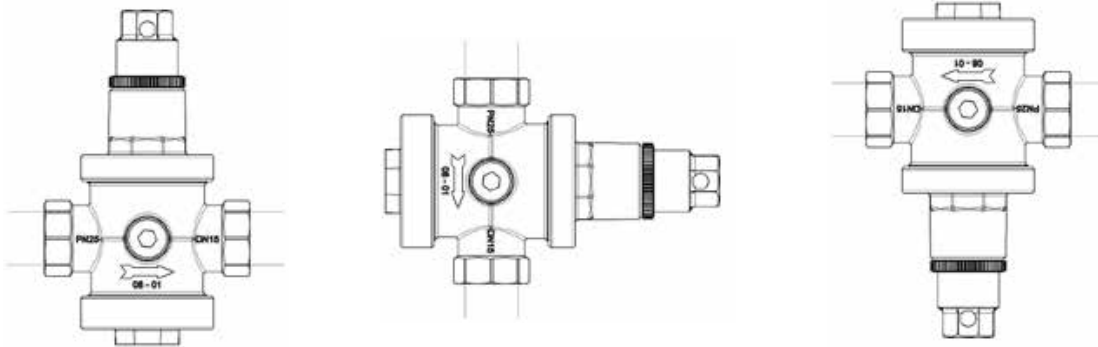

Manufacturers Instructions



FIG. 4.1

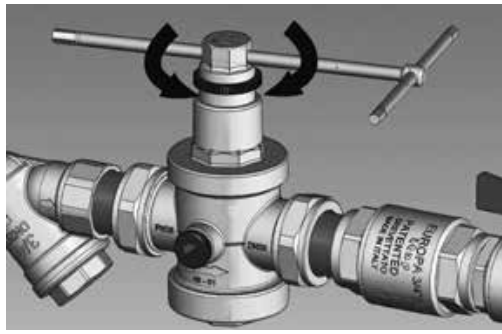

FIG. 4.2



FIG. 4.3

Instruction on installation

1. Before installing the pressure reducing valve, open all the outlets to flush the system and expel any air left in piping
2. Install shut-off valves upstream and downstream to facilitate maintenance operations
3. For a right flow direction, use the arrow stamped on the body
4. ITAP pressure reducing valve can be installed in either vertical or horizontal piping. It can be installed also upside down
5. Art. 243 is equipped with a threaded connection suitable for a pressure gauge. It is possible to unscrew the plug made in order to install a pressure gauge in the size of 1/4". In such a position, the pressure gauge shows the downstream pressure of the reducing valve.
6. The whole range of ITAP pressure reducing valves are tested and adjusted with a downstream pressure of 3 bar. It is possible to change the downstream pressure by means of the adjusting device.
7. The final adjustment of the pressure reducing valve has to be carried out with a filled private water system and with all the outlets shut-off. The upstream pressure has to be at least 1 bar higher than the adjusted pressure. Adjustment of the pressure reducing valve to a downstream pressure different from the pre-adjusted one (3 bar):
 - Close the downstream shut-off valve
 - Unscrew the nylon nut (Fig. 4.1)
 - Adjustment is carried out by means of a tool or a screwdriver on the upper part of the device (Fig. 4.2); turn in clockwise way to increase the downstream pressure, turn in anticlockwise way to reduce the downstream pressure
 - Open the outlets in the private water system, in order to check the stability of the adjusted pressure
 - Adjust the downstream pressure with outlets totally shut-off and with water at room temperature only
 - Screw the nylon nut (Fig. 4.3)
 - Adjustment procedure is complete once the required pressure appears on the pressure gauge.
8. ITAP s.p.a. recommends the use of PTFE as a sealant in junctions between pressure reducing valves and water pipings.

Manufacturers Instructions

Troubleshooting

Increase in pressure downstream on the pressure reducing valve with a water heater in-line. This problem is due to heating of the water, caused by the water heater. The pressure downstream increases, due to water expansion, as the pressure reducing valve is correctly closed. It is necessary to install an expansion vessel between the pressure reducing valve and the water heater to absorb the pressure increase (Fig. 5.1).

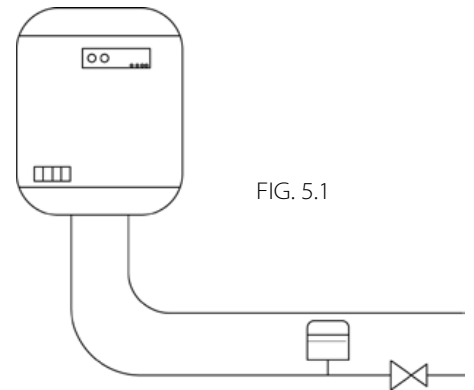

FIG. 5.1

The pressure reducing valve does not maintain the adjusted figure

In most cases, this problem is due to the presence of impurities on the valve seat, causing blow-by and consequent increase in the downstream pressure. Install an Y-strainer upstream of the pressure reducing valve. Carry-out the maintenance of the Y-strainer. Flush the water system before installing the pressure reducing valve.

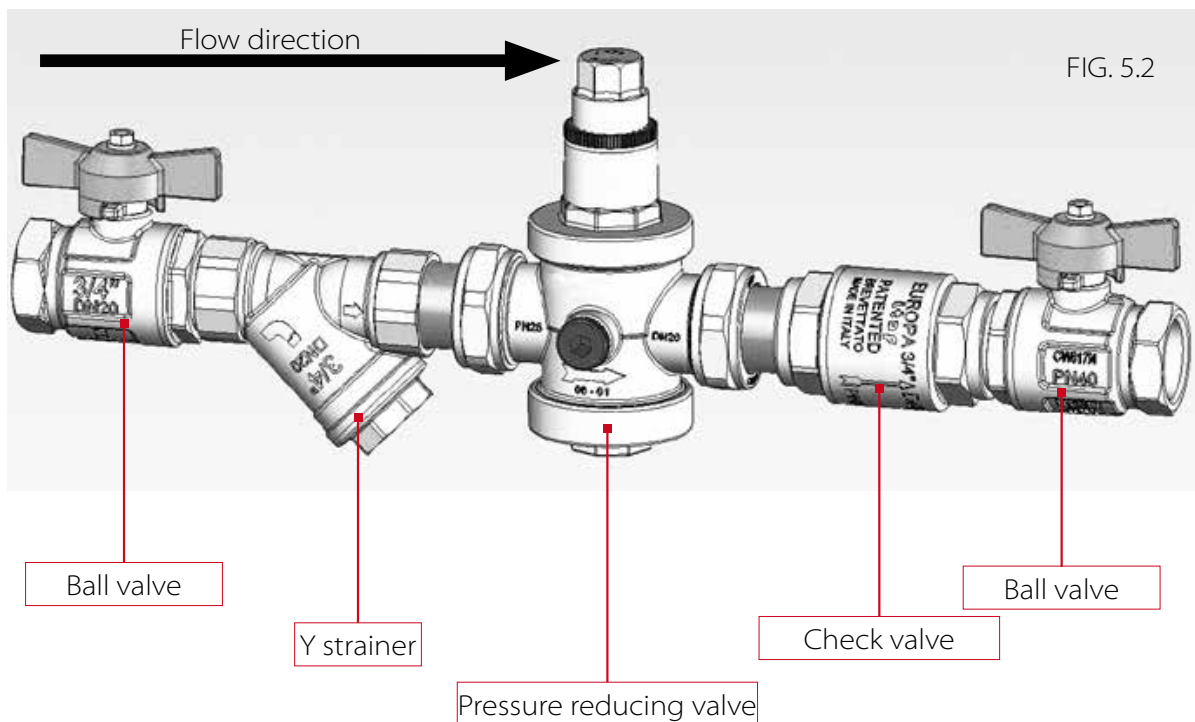

FIG. 5.2

Ball valve

Y strainer

Pressure reducing valve

Check valve

Ball valve