

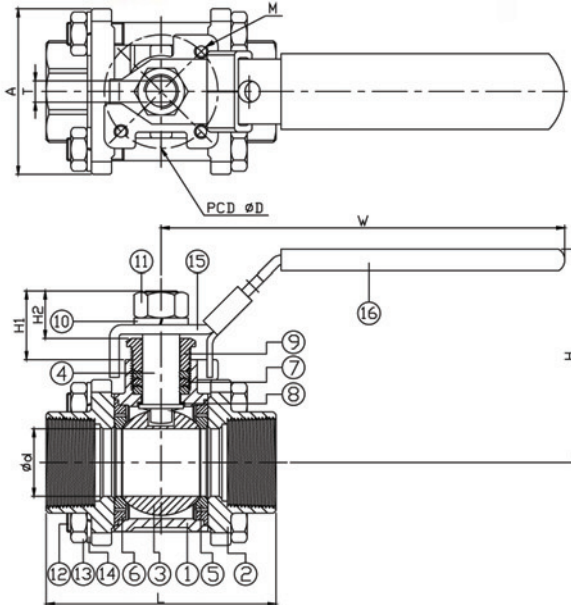

# 3-PC. SCREWED END BALL VALVE

# 2013NM

## ★ ECONOMIC PATTERN



## FEATURES

- Full port, 1/4"~4" (DN8~DN100)
- W.P. : 1000 WOG (PN63)
- W.T. : -20°C~200°C (-4°F~392°F)
- Investment casting
- Blow-out proof stem
- Locking device
- ISO 5211 Mounting pad
- TA-Luft approved
- Length conform to DIN 3202/4-M3-2013NM-M3 (option)

- Thread type : ASTM B1.20.1 (NPT)  
DIN2999 & BS21  
ISO228/1 & ISO7/1

ITEM	PARTS	MATERIAL	
1	BODY	ASTM A351-CF8M	ASTM A216-WCB
2	CAP		
3	BALL	ASTM A351-CF8M	
4	STEM	ASTM A276-316	
5	SEAT		
6	SEAL	PTFE	
7	PACKING		
8	THRUST WASHER		
9	GLAND NUT		
10	SPRING WASHER		
11	STEM NUT		
12	BOLT	AISI 304	
13	NUT		
14	SPRING WASHER		
15	HANDLE		
16	HANDLE SLEEVE	PVC	

DN	d	L	H	W	D	A	M	S	T	H1	H2	ISO 5211	Torque (N·M) Max	Weight (kg)
8	11.6	65	58.5	100	36	39.9	M5	3/8"-24UNF	5	17.2	13.3	F03	7.5	0.35
10	12.5	65	58.5	100	36	39.9	M5	3/8"-24UNF	5	17.2	13.3	F03	7.5	0.35
15	15	65	62	100	36	46.7	M5	3/8"-24UNF	5	19.4	15.3	F03	7.5	0.5
20	20	75	62	125	36	52.2	M5	7/16"-20UNF	6.5	22.4	15.4	F03	7.5	0.72
25	25	85	77	149	42	58.2	M5	7/16"-20UNF	7.9	25.6	17.8	F04	12.5	1.04
32	32	101	82	149	42	69.6	M5	7/16"-20UNF	7.9	25.6	17.8	F04	15	1.65
40	38	112	100	190	50	77.8	M6	1/2"-20UNF	10	29.7	21.8	F05	20	2.42
50	50	130	108	190	50	90.1	M6	1/2"-20UNF	10	29.7	21.8	F05	25	3.48
65	63	162	137	250	70	114.6	M8	1"-8UNC	12	39.4	30.7	F07	64	6.7
80	76	188	145	250	70	168.7	M8	1"-8UNC	12	39.4	30.7	F07	85	9.8
100	96	224	179	323	102	215.4	M12	1"-8UNC	16	53.7	43.1	F10	95	19.2

unit:mm

NPS	d	L	H	W	D	A	M	S	T	H1	H2	ISO 5211	Torque (in·lb) Max	Weight (lb)
1/4"	0.46	2.56	2.3	3.94	1.42	1.57	M5	3/8"-24UNF	0.2	0.68	0.52	F03	66.38	0.77
3/8"	0.49	2.56	2.3	3.94	1.42	1.57	M5	3/8"-24UNF	0.2	0.68	0.52	F03	66.38	0.77
1/2"	0.59	2.56	2.44	3.94	1.42	1.84	M5	3/8"-24UNF	0.2	0.76	0.6	F03	66.38	1.1
3/4"	0.79	2.95	2.44	4.92	1.42	2.06	M5	7/16"-20UNF	0.26	0.88	0.61	F03	66.38	1.59
1"	0.98	3.35	3.03	5.87	1.65	2.29	M5	7/16"-20UNF	0.31	1.01	0.7	F04	110.63	2.29
1-1/4"	1.26	3.98	3.23	5.87	1.65	2.74	M5	7/16"-20UNF	0.31	1.01	0.7	F04	132.76	3.64
1-1/2"	1.5	4.41	3.94	7.48	1.97	3.06	M6	1/2"-20UNF	0.39	1.17	0.86	F05	177.01	5.34
2"	1.97	5.12	4.25	7.48	1.97	3.55	M6	1/2"-20UNF	0.39	1.17	0.86	F05	221.27	7.67
2-1/2"	2.48	6.38	5.39	9.84	2.76	4.51	M8	1"-8UNC	0.47	1.55	1.21	F07	566.44	14.77
3"	2.99	7.4	5.71	9.84	2.76	6.64	M8	1"-8UNC	0.47	1.55	1.21	F07	752.31	21.61
4"	3.78	8.82	7.05	12.72	4.02	8.48	M12	1"-8UNC	0.63	2.11	1.7	F10	840.82	42.33

unit:in