

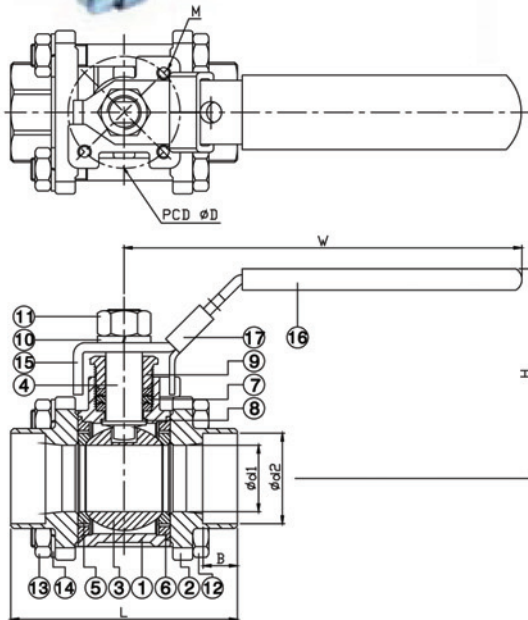

3-PC. SOCKET WELD END BALL VALVE

2011NM

★ ECONOMIC PATTERN



FEATURES

- Full port, 1/4"~4" (DN8~DN100)
- W.P. : 1000 WOG (PN63)
- W.T. : -20°C~200°C (-4°F~392°F)
- Investment casting
- Blow-out proof stem
- Locking device
- ISO 5211 Mounting pad
- TA-Luft approved
- Length conform to DIN 3202/4-M3-2011NM-M3 (option)
- Socket weld ends conform to ANSI B16.11 & DIN 3239 part2

ITEM	PARTS	MATERIAL	
1	BODY	ASTM A351-CF8M	ASTM A216-WCB
2	CAP		
3	BALL	ASTM A351-CF8M	
4	STEM	ASTM A276-316	
5	SEAT		
6	SEAL	PTFE	
7	PACKING		
8	THRUST WASHER		
9	GLAND NUT		
10	SPRING WASHER	AISI 304	
11	STEM NUT		
12	BOLT		
13	NUT		
14	SPRING WASHER	AISI 304	
15	HANDLE		
16	HANDLE SLEEVE	PVC	
17	LOCKING DEVICE	AISI 304	

DN	d1	d2	B	D	M	L	H	W	ISO 5211	Torque (N-M)		Weight (kg)
										Max		
8	11.6	14.5	10	36	M5	65	58.5	100	F03	7.5	0.35	
10	12.5	18	10	36	M5	65	58.5	100	F03	7.5	0.35	
15	15	22	10	36	M5	65	62	100	F03	7.5	0.5	
20	20	27.5	13	36	M5	75	62	125	F03	7.5	0.72	
25	25	34	13	42	M5	85	77	149	F04	12.5	1.04	
32	32	43	13	42	M5	101	82	149	F04	15	1.65	
40	38	49	13	50	M6	112	100	190	F05	20	2.42	
50	50	61	16	50	M6	130	108	190	F05	25	3.48	
65	63	74	16	70	M8	162	137	250	F07	64	6.7	
80	76	90	16	70	M8	188	145	250	F07	85	9.8	
100	96	116	20	102	M10	224	179	323	F10	95	19.2	

unit:mm

NPS	d1	d2	B	D	M	L	H	W	ISO 5211	Torque (in-lb)		Weight (lb)
										Max		
1/4"	0.46	0.57	0.39	1.42	M5	2.56	2.3	3.94	F03	66.38	0.77	
3/8"	0.49	0.71	0.39	1.42	M5	2.56	2.3	3.94	F03	66.38	0.77	
1/2"	0.59	0.87	0.39	1.42	M5	2.56	2.44	3.94	F03	66.38	1.1	
3/4"	0.79	1.08	0.51	1.42	M5	2.95	2.44	4.92	F03	66.38	1.59	
1"	0.98	1.34	0.51	1.65	M5	3.35	3.03	5.87	F04	110.63	2.29	
1-1/4"	1.26	1.69	0.51	1.65	M5	3.98	3.23	5.87	F04	132.76	3.64	
1-1/2"	1.5	1.93	0.51	1.97	M6	4.41	3.94	7.48	F05	177.01	5.34	
2"	1.97	2.4	0.63	1.97	M6	5.12	4.25	7.48	F05	221.27	7.67	
2-1/2"	2.48	2.91	0.63	2.76	M8	6.38	5.39	9.84	F07	566.44	14.77	
3"	2.99	3.54	0.63	2.76	M8	7.4	5.71	9.84	F07	752.31	21.61	
4"	3.78	4.57	0.79	4.02	M10	8.82	7.05	12.72	F10	840.82	42.33	

unit:in