

Ra	0.2	▽▽▽▽
1.6	▽▽	▽▽▽
6.3	▽	▽▽
25	▽	▽
Q	~	

GENERAL TOLERANCE	0.5-5	± 0.1
	6-30	± 0.2
	31-120	± 0.3
	121-320	± 0.5
	321-1000	± 0.8

HAITIMA CORPORATION
 P.O.BOX 34-36 TAIPEI
 Tel:+886-2-26585800
 E-mail:haitima@seednet.tw
 TAIWAN R.O.C. www.haitimo.com.tw
 Fax:+886-2-26582266

WELDING NIPPLE

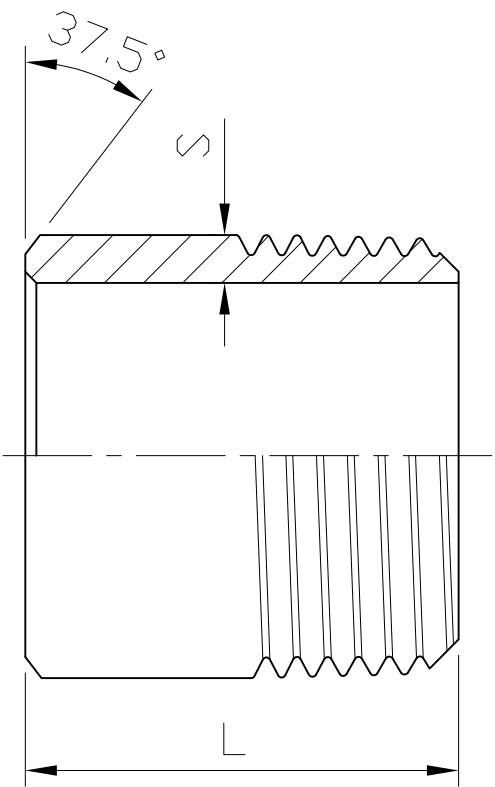

SIZE	1/8"		1/4"		3/8"		1/2"		3/4"		1"		1-1/4"		1-1/2"		2"		2-1/2"		3"		4"	
	mm	in	mm	in	mm	in	mm	in	mm	in	mm	in	mm	in	mm	in	mm	in	mm	in	mm	in	mm	in
S	1.7	0.07	2	0.08	2	0.08	2.5	0.1	2.5	0.1	3.2	0.13	3.2	0.13	3.2	0.13	3.6	0.14	3.6	0.14	4	0.16	4.5	0.18
L	30	1.18	30	1.18	30	1.18	35	1.38	40	1.57	40	1.57	50	1.97	50	1.97	50	1.97	60	2.36	70	2.76	80	3.15

Tolerance: ± 0.5mm(1/8"~2")
 ± 0.8mm(2-1/2"~4")

△			
△			
△			
Revise	Description	Date	Approve
DRAWING NO. F09		-08	

HAITIMA CORPORATION
 Ball Valves & Pipe Fittings

CHECK BY	DRAWING BY	DATE	SPECIFICATION
	Dune	May.22.2008	Welding Nipple
			MATERIAL 304/316
			PROCESS/No.
			SCALE mm