

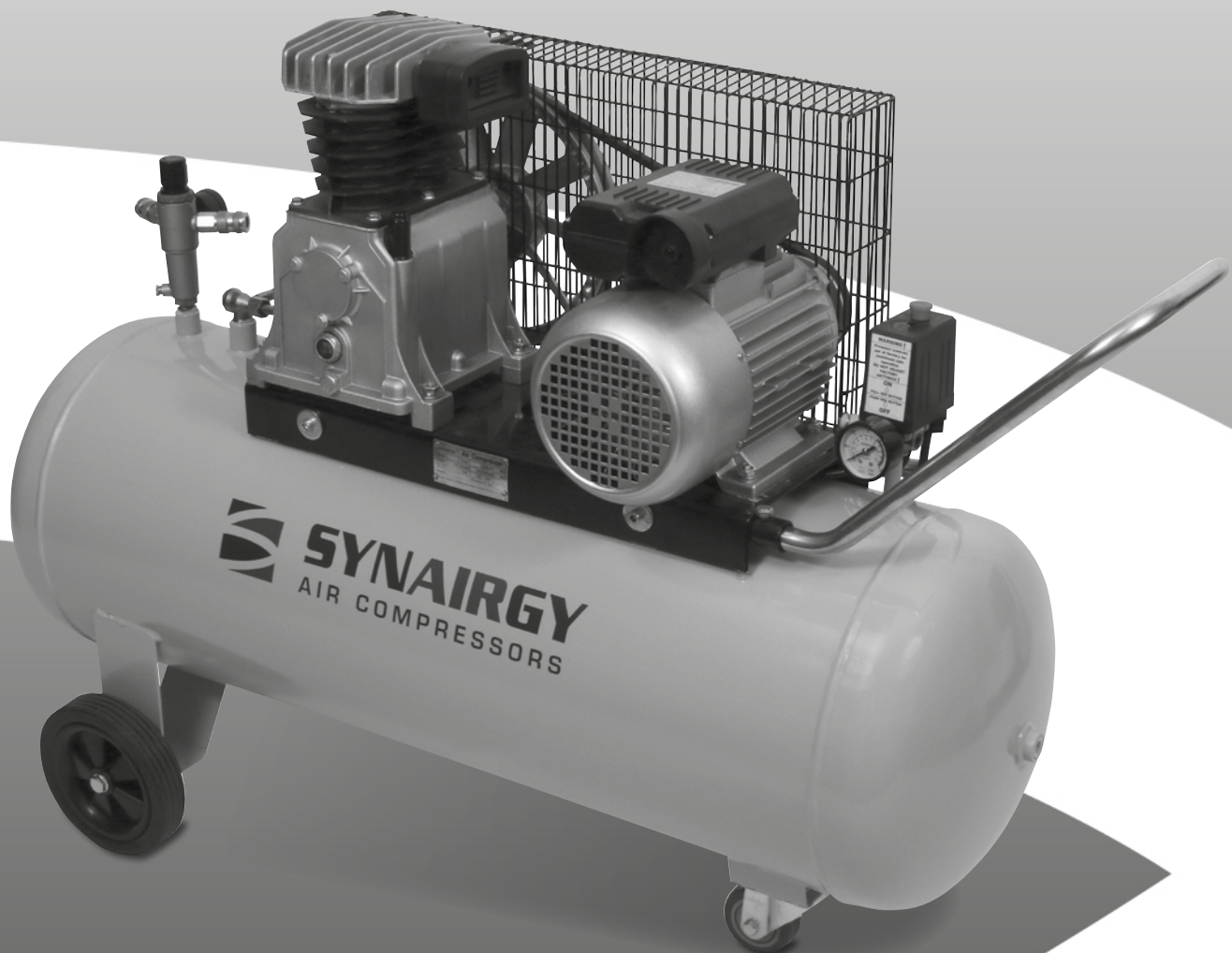

SYNAIRGY
AIR COMPRESSORS

Belt Driven Compressor Operation Manual

Model No. SACBD-100





Contents



Important Notice	3
Preparation for Usage	3
Safety Guidelines	4-5
Caution	6
Brief Description	6
Compressor Overview	7
Technical Specification	7
Parts List	8-9
Operation and Adjustment	10
Maintenance	10
Troubleshooting	11

Important Notice

1. In order to operate this compressor, please read and fully understand the instructions contained in this manual before use. The compressor should only be operated by professional personnel who fully abide by the safety instructions contained herein.
2. Keep the compressor away from flammable materials and heat sources.
3. Switch off the power supply and release the compressed air before each maintenance or repair. Ensure warning stickers are displayed to avoid accidental use during this period.
4. It is strictly prohibited to change the factory's settings without manufacturer's prior written consent.

Preparation for Usage

1. The Air compressor should be placed in a clean, dry and ventilated area
2. In order to extend the compressor lifespan, reduce the heat of moving parts by making sure the air compressor cover is at least 0.3 - 0.5 metres away from the wall
3. Keep the voltage within $\pm 5\%$ of rating
4. Keep the oil level within the indicator
5. Recommended compressor oil AC2100 or AC2032
6. The normal working temperature should be -5°C - $+35^{\circ}\text{C}$
7. The normal working temperature of the air compressor is 180°C and the lubricating oil in the crankcase is 70°C
8. Open the outlet valve and let the air compressor run for 10 minutes without load before operation



Safety Guidelines

DANGER

- 1. TO REDUCE THE RISK OF FIRE OR EXPLOSION, NEVER SPRAY FLAMMABLE LIQUIDS IN A CONFINED AREA.** It is normal for the motor and pressure switch to produce sparks while operating. If sparks come into contact with vapours from gasoline or other solvents, it may ignite fire or an explosion. The air compressor must be stored and operated in a well-ventilated area. Do not smoke while using the air compressor, and keep away from flammable material
- 2.** When Trichloroethane and Methylene Chloride come into contact with aluminium in painting equipment, it can produce a chemical reaction which may cause an explosion. If you are using these solvents, please use only stainless steel spray equipment.
- 3.** Never directly inhale the compressed air produced by a compressor.

Safety Guidelines

WARNING

1. Do not weld onto the air tank of this compressor. Welding on the air compressor tank will cause a safety hazard and will void the product warranty
2. Never use an electric air compressor outdoors or on a wet surface; it may cause an electric shock
3. Please power off the air compressor when not in use
4. Check the manufacturer's maximum pressure rating for air tools and accessories. The compressor outlet pressure must be regulated so as not to exceed the maximum pressure rating for the tools
5. High temperatures and moving parts are present under the outer cover. To prevent burns or other injuries, DO NOT operate with the outer cover removed. Allow the compressor parts to cool before handling or servicing
6. Ensure you read all labels when you are spraying paints or toxic materials; follow the safety instructions provided, and use a respirator mask
7. Always wear safety goggles or glasses when using an air compressor. Never point any nozzle or sprayer towards a person or any part of the body
8. Do not adjust the pressure switch or regulating valve for any reason; they have been pre-set at the factory for the maximum pressure for this unit

CAUTION:

1. Drain the moisture from the tank on a daily basis. A clean, dry tank will help prevent corrosion
2. Pull off the pressure relief valve ring daily to ensure that the valve is functioning properly, and to clear any obstructions
3. To provide adequate ventilation for cooling, the compressor must be kept a minimum of 0.3-0.5 metres from the nearest wall, in a well-ventilated area
4. Fasten the compressor down securely, and release the pressure from the tank before transportation
5. Protect the air hose and electrical wire from damage and punctures. Inspect them weekly for weak or worn spots, and replace them if necessary



Caution

1. Pull the cover off and connect the breather pipe and air filter before running the compressor
2. Never unscrew any connecting parts when the tank is pressurised
3. Disconnect the plug before disassembling any electrical part
4. Do not adjust the pressure switch or regulating valve for any reason; they have been pre-set at the factory for the maximum pressure of this unit
5. Never use the compressor when the voltage is too low or too high
6. Never use electrical wire more than 5m long
7. Never disconnect the plug to stop the compressor; turn the switch to off instead
8. If the outlet valve doesn't work, search for the cause immediately so as not to damage the motor
9. Lubricating oil must be clean; the oil level should be kept within the indicator
10. Before opening the outlet valve ensure the compressor is switched off and the plug is disconnected from the power supply
11. The maximum decibel of the compressor is 89db

Brief Description

This range of Synairgy belt driven air compressors are built with performance and reliability in mind. These units are designed for use in industrial and commercial environments, with the air capacity and power to drive many of the most commonly used air compressor tools. Easy operation, excellent safety characteristics and low noise levels make this compressor ideal for typical applications and will satisfy the requirements for most garages, small factories, workshops and farms where compressed air is required.

It is recommended that larger air compressors such as this are fitted with heavy-duty anti-vibration floor mountings.

Compressor Overview

1. Safety guard
2. Motor
3. Air pump
4. Air tank
5. Air regulator
6. Wheel
7. Handle
8. Safety relief valve

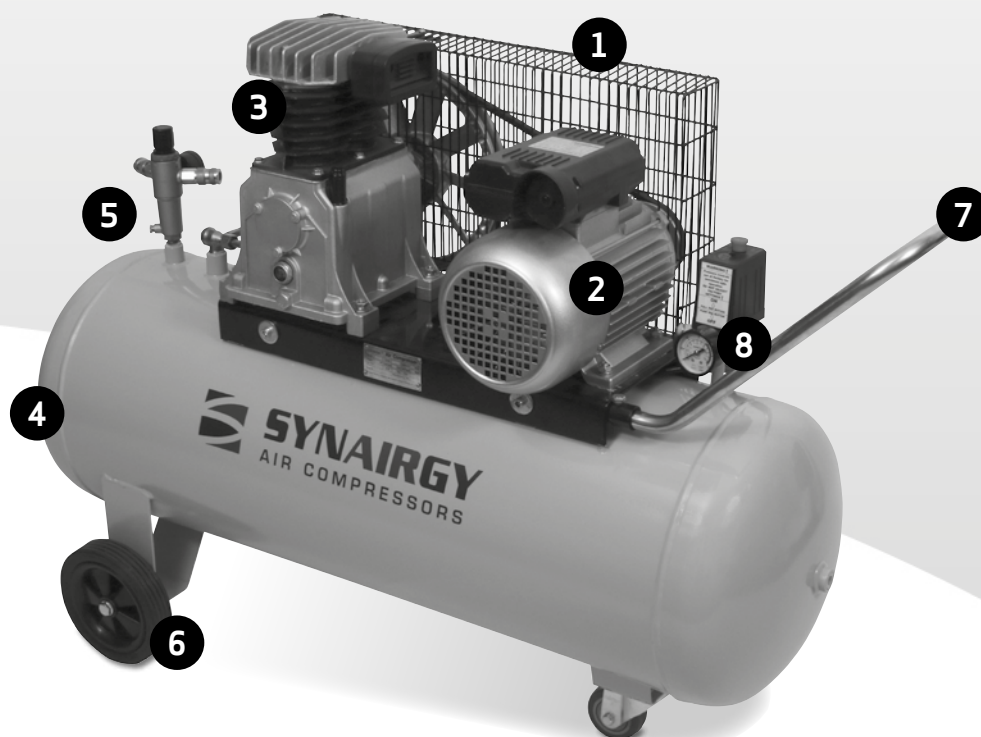

Technical Specification

Code	Voltage		Power		Cylinder	Rated Speed	Capacity		Pressure	Tank		N.W
	V/Hz	KW	hp	mm*n	rpm	l/min	C.F.M	bar/psi	L	Usgal	kg	
SACBD-100	220/50	2.2	3.0	Ø55*2	1050	200	7.1	8/115	100	6.34	89	



Parts List

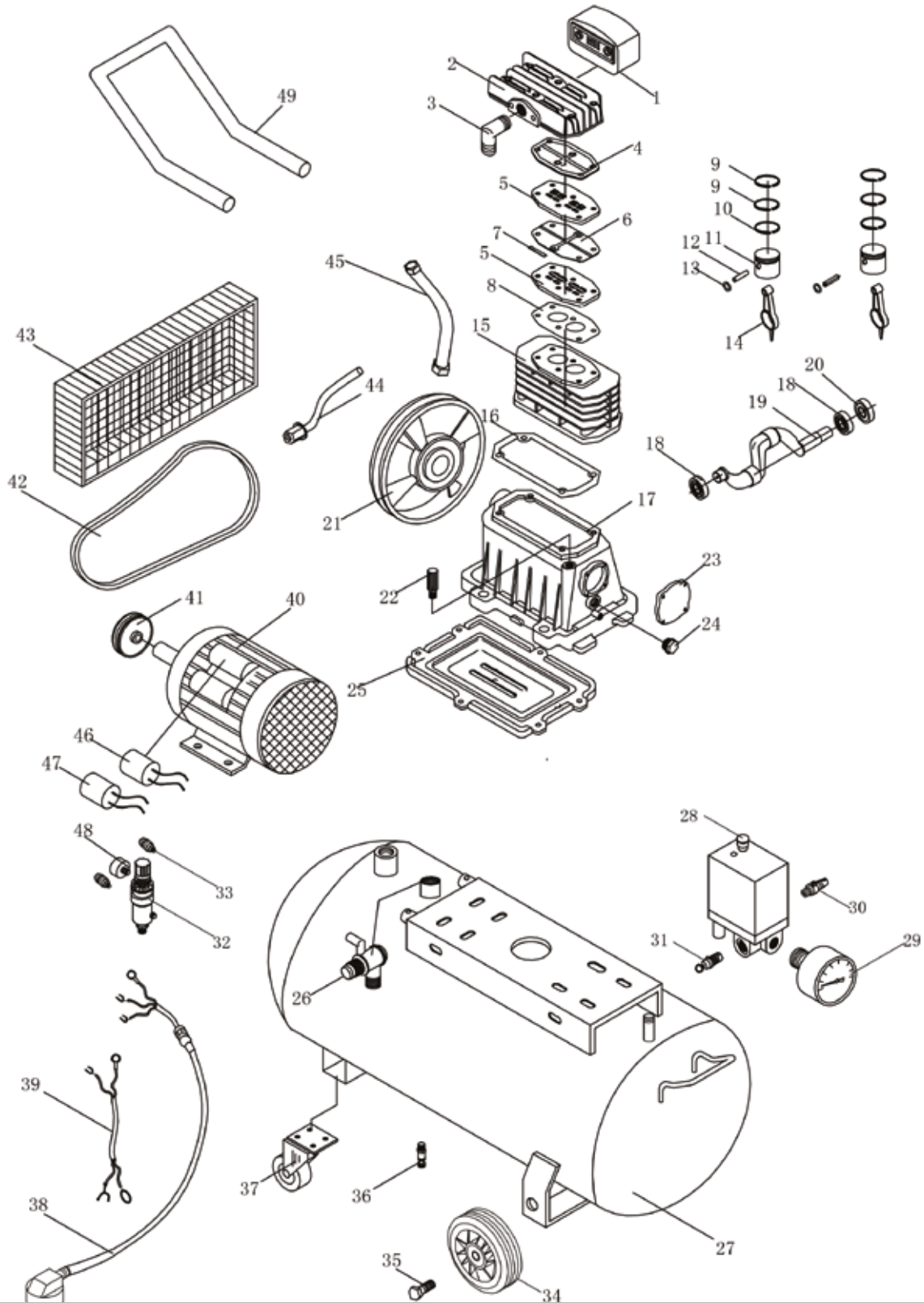

Parts List

No.	Designation	Qty
1	Air filter	1
2	Cylinder head	1
3	Connector	1
4	Cylinder head gasket	1
5	Valve plate	2
6	Valve plate copper gasket	1
7	Valve cock	4
8	Valve plate gasket	1
9	Piston ring	4
10	Oil ring	2
11	Piston	2
12	Piston pin	2
13	Piston circlip	2
14	Connecting rod	2
15	Cylinder	1
16	Cylinder gasket	1
17	Crank case	1
18	Bearing	2
19	Crank shaft	1
20	Oil seal	1
21	Pump pulley	1
22	Breather pipe	1
23	Crank case side cover	1
24	Oil level indicator	1
25	Baseboard for crank case	1
26	Check valve	1
27	Air tank	1
28	Air switch	1

No.	Designation	Qty
29	Pressure gauge 50mm	1
30	End cap	1
31	Safety relief valve	1
32	Regulating valve	1
33	Air outlet	2
34	Wheel	2
35	Wheel axle	2
36	Water release valve	1
37	Rotary wheel	1
38	Power cable	1
39	Motor wire	1
40	Motor	1
41	Motor pulley	1
42	Belt	1
43	Safety guard	1
44	Release pipe	1
45	Discharge pipe	1
46	Starting capacitor	1
47	Working capacitor	1
48	Pressure gauge 40mm	1
49	Handle	1

Operation and Adjustment

1. Open the drain cock under the tank and then close it.
2. The compressor is controlled by the pressure switch. It can be stopped automatically as pressure increases to the maximum and restarted as pressure decrease to the minimum. The rated pressure has been set during production; do not adjust needlessly. As soon as the motor is switched off the compressed air in the discharge pipe should be released through the outlet valve under the switch, this is required for restarting, or the motor will be damaged. The rated pressure can be adjusted by turning the adjusting bolt of the switch.
3. The outlet pressure of compressed air can be adjusted, by the regulating valve (Fig.3). Pull up the knob of the regulation valve and turn it clockwise to increase the pressure.
4. When the compressor needs to be stopped, set the switch to the off position.

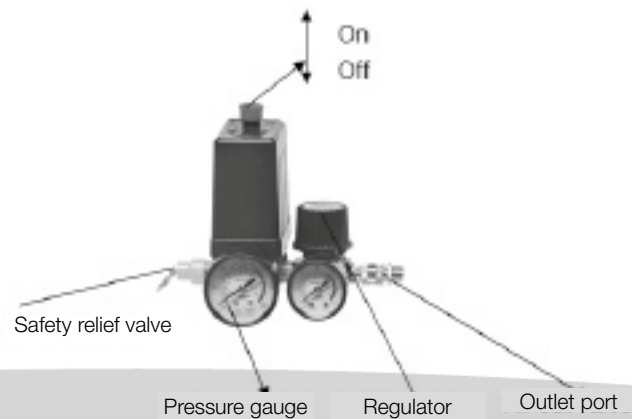

(Fig.3)

Maintenance

1. Clean the crankcase and replace the lubricating oil after the first 10 working hours
2. Check the oil level after every 20 working hours, and replenish it if necessary
3. Open the drain cock under the tank to exhaust condensation after every 60 working hours
4. Clean the crankcase every 120 working hours and renew the oil, clean the air filter, check the safety valve and pressure gauge

Troubleshooting

Problem	Possible Causes	Solution
Motor unable to run, running too slowly or getting hot	<ol style="list-style-type: none"> 1. Fault in the line or insufficient voltage 2. Power voltage is too low 3. Fault with the pressure switch 4. Fault with the motor 5. Sticking of main compressor 	<ol style="list-style-type: none"> 1. Check the wire connection from the motor to the switch 2. Voltage should be above 190V 3. Replace pressure switch 4. Check motor wire connection and cable - if the cable is burnt or damaged replace with new cable
Sticking of main compressor	<ol style="list-style-type: none"> 1. Moving parts are burnt due to insufficient oil or moving parts are damaged or stuck by a foreign body 	<ol style="list-style-type: none"> 1. Check the crankcase, bearing, connecting rod, piston, piston ring and replace if necessary
Shaking or abnormal noise	<ol style="list-style-type: none"> 1. Loose connecting part 2. Foreign body in main compressor 3. Piston knocking valve seat 4. Worn moving parts 	<ol style="list-style-type: none"> 1. Check and retighten 2. Check and remove 3. Replace gasket 4. Repair or replace
Insufficient pressure or discharge capacity decreased	<ol style="list-style-type: none"> 1. Motor runs too slowly 2. Air filter blocked 3. Safety relief valve leaking 4. Discharge pipe leaking 5. Sealing gasket damaged 6. Valve plate damaged, carbon build up or stuck 7. Piston ring and cylinder worn or damaged 	<ol style="list-style-type: none"> 1. Check voltage in the power socket 2. Clean or replace the cartridge 3. Replace with a new one 4. If the tube connector leaks air try to fasten it. If main body or discharge pipe leaks oil, replace with new one. 5. Open and check whether it is damaged, if it is replace it with new one. 6. Check and replace it 7. Replace
Excessive oil consumption	<ol style="list-style-type: none"> 1. The oil level is too high 2. Breather pipe is blocked 3. Piston ring and cylinder worn or damaged 	<ol style="list-style-type: none"> 1. Keep the level within the set range (in the middle of oil indicator) 2. Check and clean 3. Replace with new one

