

M 2-PC. FLANGED END BALL VALVE

2019D



FEATURES

- Full port, 1/2"~4" (DN15~DN100)
- W.P. : PN16/40
- W.T. : -20°C~200°C (-4°F~392°F)
- Investment casting
- Blow-out proof stem
- Live-loading design
- Anti-static device
- Locking device
- ISO 5211 direct mounting pad
- **API 607 Fire safe approved**
- **ISO 15848 fugitive emission approved (option)**
- **Automation accessories (option)**

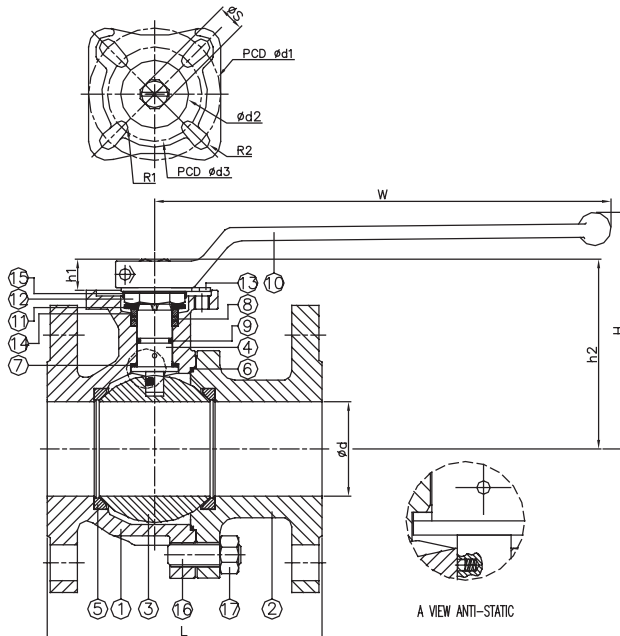

ITEM	PARTS	MATERIAL	
1	BODY	ASTM A351-CF8M	ASTM A216-WCB
2	CAP		
3	BALL	ASTM A351-CF8M	
4	STEM	ASTM A276-316	
5	SEAT	PTFE	
6	SEAL	GRAPHITE	
7	THRUST WASHER	CTFE	
8	PACKING	GRAPHITE	
9	O-RING	VITON	
10	HANDLE	AISI 304	
11	BELLEVILLE WASHER	AISI 301	
12	STEM NUT		
13	LOCKING DEVICE		
14	GLAND RING	AISI 304	
15	LOCKING WASHER		
16	BOLT		
17	NUT		

- ABOVE MENTIONED MATERIALS APPLY TO FIRE SAFE DESIGN
 - ISO 15848 DESIGN SHOULD REPLACE WITH PTFE SEAL & PACKING

	DN	d	L	H	W	ISO 5211	S	h1	h2	d2	d3	d1	R1	R2	Torque(N-m)	Weight(kg)
PN16-40	15	15	115	86.5	197	F03 \ F04	9	8.5	60	26	36	42	2.75	2.75	5.2	2.2
	20	20	120	89	197	F03 \ F04	9	8.5	62.5	26	36	42	2.75	2.75	8	2.8
	25	24	125	93	197	F04 \ F05	11	11	69	30.5	42	50	2.75	3.5	12.5	3.6
	32	30	130	106	197	F04 \ F05	11	11	82	30.5	42	50	2.75	3.5	12	5.3
	40	38	140	121	247	F05 \ F07	14	15	91	36	50	70	3.5	4.5	24.5	6.6
PN16	50	50	150	129	247	F05 \ F07	14	15	99	36	50	70	3.5	4.5	32	9.4
	65	64	170	158	340	F07 \ F10	17	22	127	47	70	102	4.5	5.5	38	13.8
	80	76	180	166	340	F07 \ F10	17	22	134.5	47	70	102	4.5	5.5	45	17.9
	100	100	190	189	340	F10 \ F12	22	24	160	57	102	125	6.5	7.5	55	23.6

unit:mm

	NPS	d	L	H	W	ISO 5211	S	h1	h2	d2	d3	d1	R1	R2	Torque(in-lb)	Weight(lb)
PN16-40	1/2"	0.59	4.53	3.41	7.76	F03 \ F04	0.35	0.33	2.36	1.02	1.42	1.65	0.11	0.11	46	4.9
	3/4"	0.79	4.72	3.5	7.76	F03 \ F04	0.35	0.33	2.46	1.02	1.42	1.65	0.11	0.11	70.8	6.2
	1"	0.94	4.92	3.66	7.76	F04 \ F05	0.43	0.43	2.72	1.2	1.65	1.97	0.11	0.14	110.6	8
	1-1/4"	1.18	5.12	4.17	7.76	F04 \ F05	0.43	0.43	3.23	1.2	1.65	1.97	0.11	0.14	106.2	11.7
	1-1/2"	1.5	5.51	4.76	9.72	F05 \ F07	0.55	0.59	3.58	1.42	1.97	2.76	0.14	0.18	216.8	14.6
PN16	2"	1.97	5.91	5.08	9.72	F05 \ F07	0.55	0.59	3.9	1.42	1.97	2.76	0.14	0.18	283.2	20.7
	2-1/2"	2.52	6.69	6.22	13.39	F07 \ F10	0.67	0.87	5	1.85	2.76	4.02	0.18	0.22	336.3	30.3
	3"	2.99	7.1	6.54	13.39	F07 \ F10	0.67	0.87	5.3	1.85	2.76	4.02	0.18	0.22	398.3	39.5
	4"	3.94	7.48	7.44	13.39	F10 \ F12	0.87	0.94	6.3	2.24	4.02	4.92	0.26	0.3	486.8	52

unit:in