

### CustomCrimp® HS Models

The HS150 (1 HP) saw is capable of cutting up to 1-1/4 inch 4 wire hose and up to 1 inch 6 wire hose.  
The HS300 (3 HP) saw is capable of cutting up to 1-1/4 inch 6 wire or 2 inch 2 wire hose.  
The HS500 (5 HP) saw is capable of cutting up to 2 inch 6 wire hose with the serrated blade installed.

### Installation

Mount the saw on a sturdy workbench.

The HS150 Hose Saw is only available in 230V single phase configuration.

For the HS300 and HS500 Saws:

Make certain that the electric service is correct for the saw. The HS 300 and HS 500 saws are available in:  
3 HP and 5 HP 220 Volt Single Phase  
3 HP and 5 HP ••••• Volt 3 Phase

**Check the blade rotation. The top of the blade should rotate towards the front of the saw. If rotation is not correct on a 3 phase saw, reverse any two of the hot wires.**

**Always wear safety Glasses**  
**Allow the blade to reach full speed before starting a cut**  
**Periodically examine the blade for cracks and/or broken teeth.**  
**Replace if necessary.**  
**Do not remove or defeat any of the guards or safety features of the saw**

### Coolant Flow Adjust

### Air Flow Adjust

### Mister Installation (Optional)

A Mister Kit (P/N 103172) is available for both the HS 300 and HS 500 Hose Saws. The mister sprays a fine mist of air tool oil on the saw blade for longer blade life and cleaner cuts. Adjust the air pressure and flow control to spray a fine mist on the blade. Addition of a mister kit will give smoother, cleaner cuts and prolong blade life.



### Hose Channel System (Optional)

A Hose Channel System (P/N 103073) is available in 5 foot sections for the HS300 & HS500 models. The Hose Channel System both measures and supports the hoses up to 2 inch diameter as they are being cut.



### Hose Helper (Standard on HS300 & HS500)

A "Hose Helper" attachment for the HS300 & HS500 prevents the hose from being drawn back during a cut and gives the operator the ability to more precisely control the cut length. The "Hose Helper" can be mounted on either end of the saw.

### Counter (HS300 & HS500 Models only)

A resetable counter makes it easy to keep track of the number of cuts made.

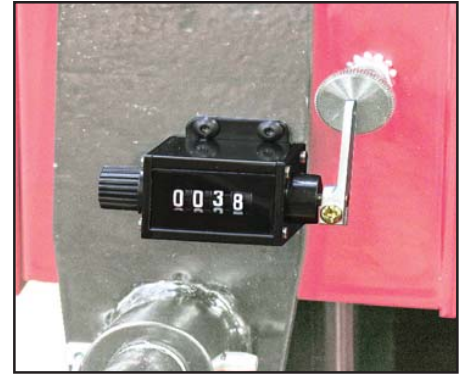

### Hose Bending Pins

Hose Bending Pins prevent the blade from binding during a cut.

Pins should be positioned in the holes in the saw table such that the hose opens slightly during the cut. Spread the pins further apart for larger hoses.

The hose should begin to bend before contacting the blade. This will increase blade life and keep the hose from tearing and deforming.

Apply steady downward pressure on the handle in order to force the hose into the blade. Do not apply enough force to stall the blade, and ease up on the pressure before the blade completes the cut. This will keep from separating the wires as the blade exits the hose.



### Blade Choice

Two blades are available. Choose the correct blade for the type of hose being cut.

**Note: New blades must be properly conditioned to assure long life and clean cuts. For the first ten cuts, feed the blade slowly through a medium size hose. this will properly break in and condition the blade for long life.**



### Double Bevel Blade with SS Slots

The double bevel smooth blade (P/N 102210) is recommended for braided hose and will give minimal debris in the cut hose.

### Serrated Blade (General Purpose)

The serrated blade (P/N 103187) is recommended for all spiral hose.

**Note: The edges of the blade may appear to be dull. This does not mean that the blade is not effective. As long as the blade is still giving clean cuts, do not replace the blade.**

**NOTE: PAY CLOSE ATTENTION TO THE DIRECTION OF ROTATION MARKED ON THE BLADE. IT IS THE OPPOSITE OF MOST BLADES OF THIS TYPE.**

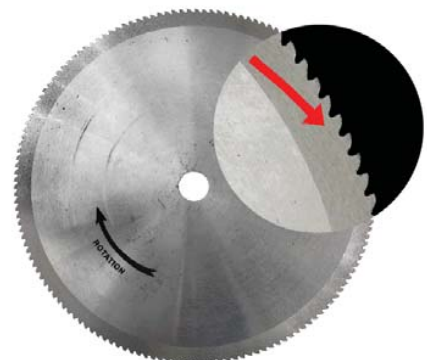

## Change Saw Blade

Remove the 5 screws holding the Side cover in place and remove the side cover.

Remove the 2 No 10-24 screws holding the black Saw Blade Access Panel in place and remove the insert in order to provide clearance to remove the blade.

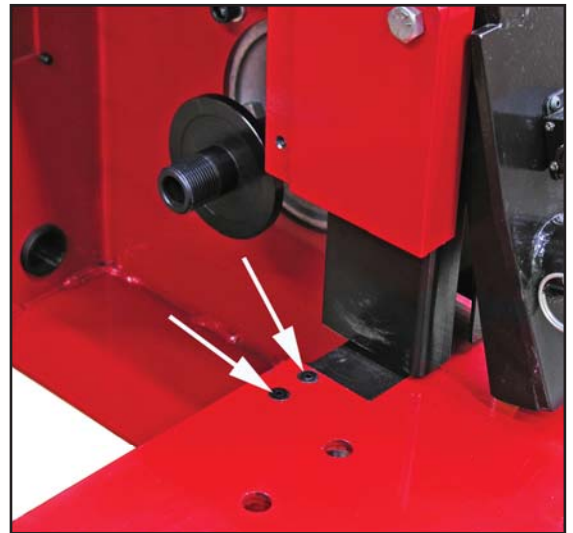

Hold the arbor in place with a wrench and remove the nut holding the saw blade. There are wrench flats on the arbor behind the blade. **(Note that this is a left handed nut).**

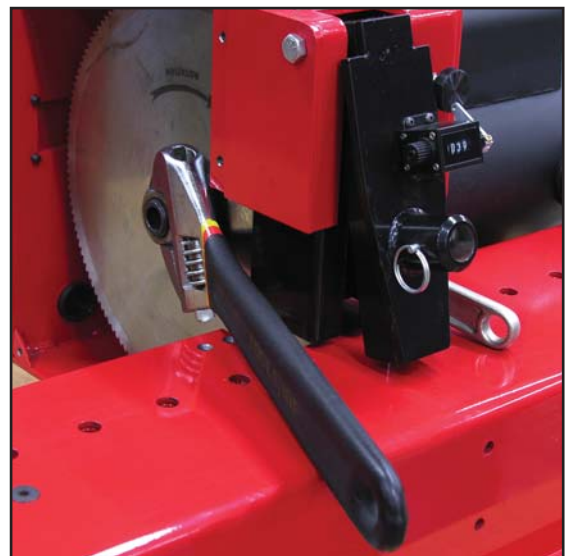

When replacing a blade, if the blade has a rotation arrow, make certain that the blade is mounted so that it rotates in the direction of the arrow.

Replace the Saw Blade Access Panel insert and the Side Cover.

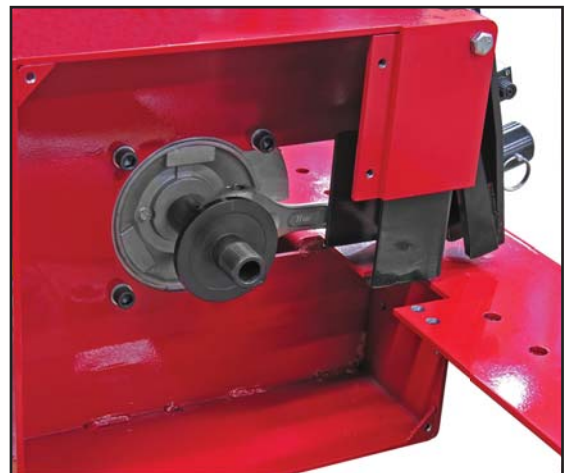

**DO NOT OPERATE THE SAW WITHOUT  
ALL OF THE GUARDS IN PLACE**

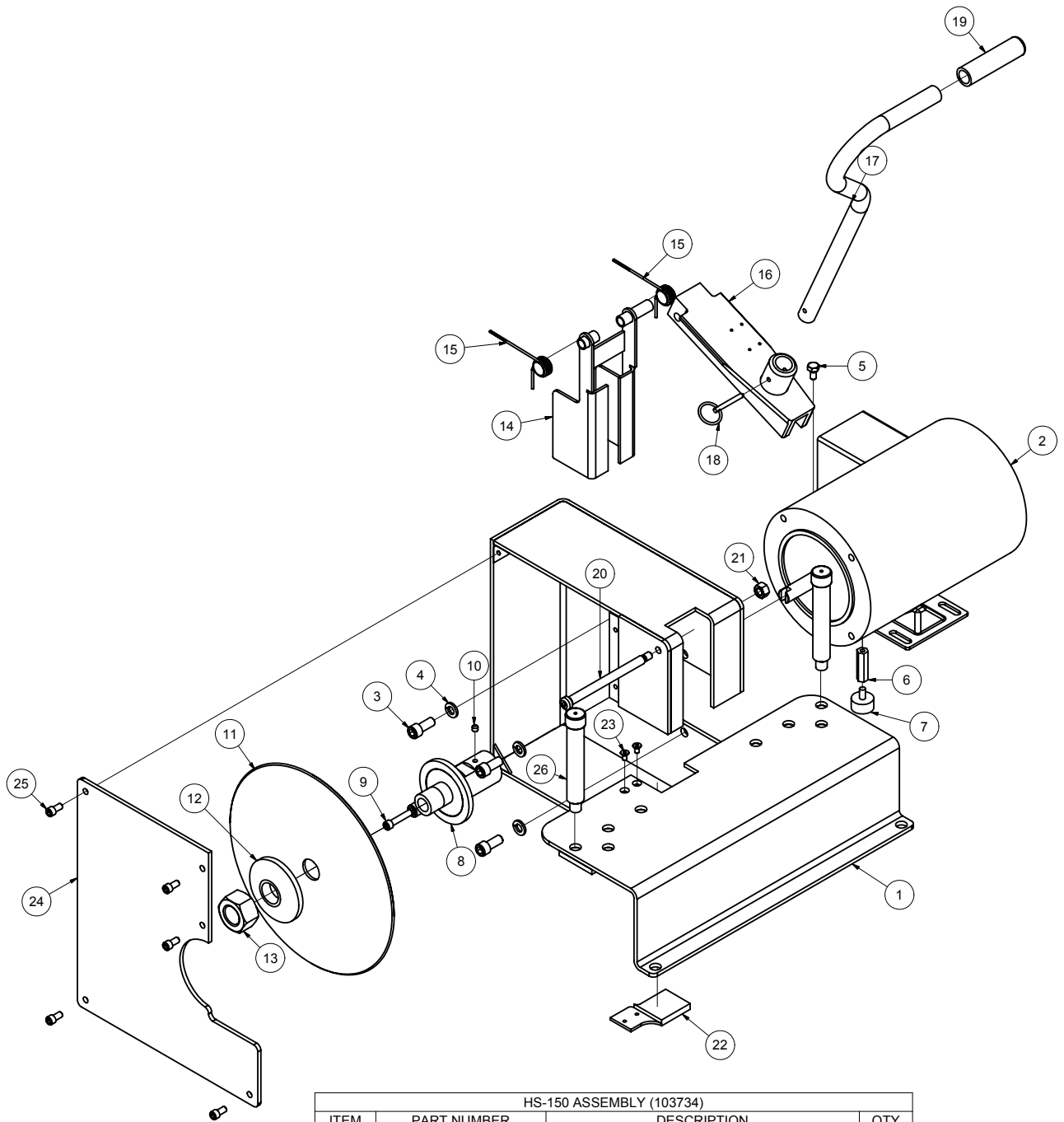

HS-150 ASSEMBLY (103734)			
ITEM	PART NUMBER	DESCRIPTION	QTY
1	103454	HS150 BASE ASSEMBLY	1
2	103814	1 HP 110V 3600RPM MOTOR	1
3	91251A623	3/8-16 X 7/8 SHCS	4
4	91101A031	3/8 LOCK WASHER	4
5	92620A537	1/4-20 X 1/2 HHS	1
6	92230A330	1/4-20 X 1-1/2" HEX STANDOFF	1
7	103774	1/4-20 RUBBER VIBRATION FOOT	1
8	103127	HS-150/300/500 5/8" MOTOR SHAFT ARBOR	1
9	91251A544	1/4-20 X 1 1/4 SHCS	1
10	91375A533	1/4-20 X 1/4 SET SCREW	1
11	103502	10 INCH SERRATED BLADE	1
12	102391	HS-150/300/500 BLADE GRIP	1
13	90083A260	1/14 LEFT HAND JAM NUT	1

ITEM/PART NUMBER	DESCRIPTION	QTY
1	HS 300V/HS 500 ASSEMBLY (103335)	1
2	HS 300V/HS 500 Base Assembly	1
3	Motor Assembly	1
4	3/8"-16 X 7/8" SHCS	4
5	12" Double Beveled Saw Blade	1
6	12" Serated Saw Blade	1
7	Blade Grip Part 2	1
8	1" Hex Jam Nut	1
9	Removable Side Cover	1
10	91255A537 1/4"-20 X 1/2" BHCS	9
11	1029206 Saw Blade Access Panel	1
12	91253A238 10.24 X 1/4" FHCS	2
13	102689 Handle Pusher	1
14	98320A013 Pull Pin	1
15	102706 Safety Guard	1
16	102697 Handle	1
17	103815 Black Hand Grip	1
18	103065 Mist Cover Plate	1
19	91257A644 3/8"-16 X 5" HHCS	1
20	94846A031 3/8"-16 Hex Nut	1
21	9271K67 Spring	2
22	103154 Fixed Bracket Assembly	1
23	91253A580 5/16"-18 X 5/8" FHCS	2
24	103665 Locating Pin Assembly	2

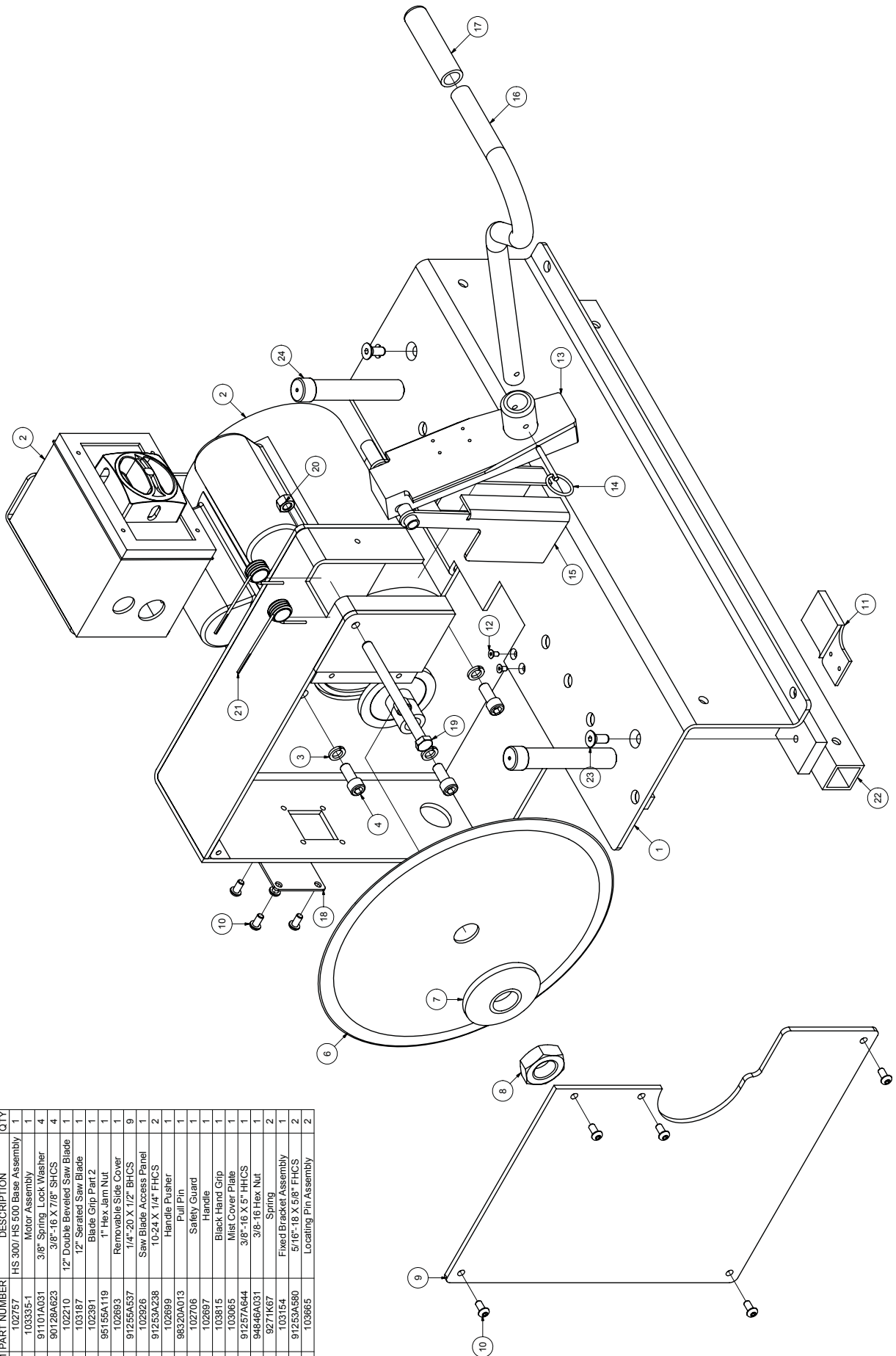

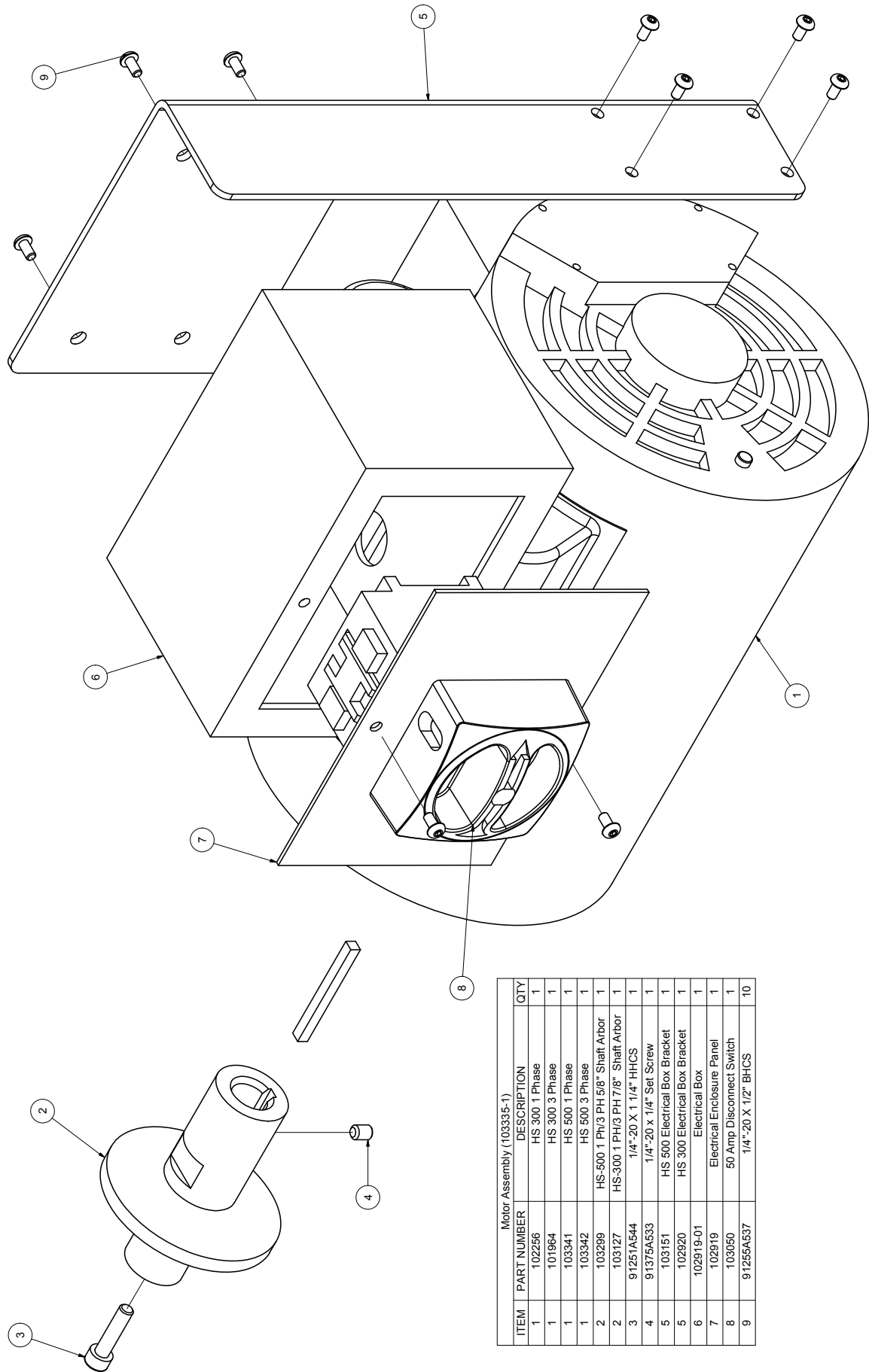

Motor Assembly (103335-1)

ITEM	PART NUMBER	DESCRIPTION	QTY
1	102256	HS 300 1 Phase	1
1	101964	HS 300 3 Phase	1
1	103341	HS 500 1 Phase	1
1	103342	HS 500 3 Phase	1
2	103299	HS-500 1 PH/3 PH 5/8" Shaft Arbor	1
2	103127	HS-300 1 PH/3 PH 7/8" Shaft Arbor	1
3	91251A544	1/4"-20 X 1 1/4" HHCS	1
4	91375A533	1/4"-20 x 1/4" Set Screw	1
5	103151	HS 500 Electrical Box Bracket	1
5	102920	HS 300 Electrical Box Bracket	1
6	102919-01	Electrical Box	1
7	102919	Electrical Enclosure Panel	1
8	103050	50 Amp Disconnect Switch	1
9	91255A537	1/4"-20 X 1/2" BHCS	10

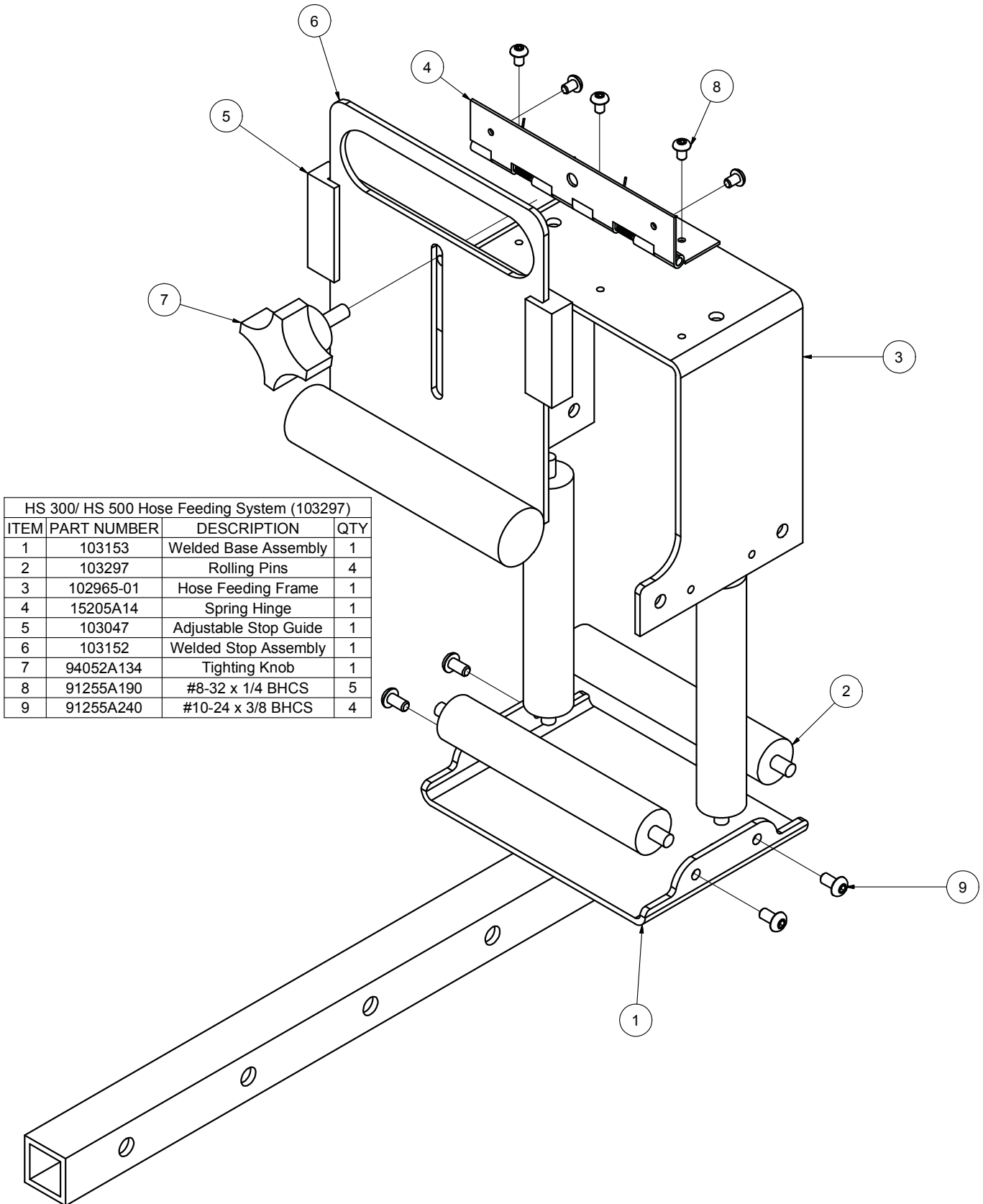

HS 300/ HS 500 Hose Feeding System (103297)			
ITEM	PART NUMBER	DESCRIPTION	QTY
1	103153	Welded Base Assembly	1
2	103297	Rolling Pins	4
3	102965-01	Hose Feeding Frame	1
4	15205A14	Spring Hinge	1
5	103047	Adjustable Stop Guide	1
6	103152	Welded Stop Assembly	1
7	94052A134	Tightening Knob	1
8	91255A190	#8-32 x 1/4 BHCS	5
9	91255A240	#10-24 x 3/8 BHCS	4