



SAFETY PRECAUTIONS



READ INSTRUCTIONS AND IDENTIFY ALL COMPONENT PARTS BEFORE USING CRIMPER

KEEP HANDS AWAY FROM PINCH POINTS

CONSULT HOSE AND FITTING MANUFACTURER'S SPECIFICATIONS FOR CORRECT MACHINE SETTINGS AND CRIMP MEASUREMENTS

ALWAYS WEAR EYE PROTECTION

SAFETY PRECAUTIONS -----	2
INDEX-----	3
COMPONENT PARTS IDENTIFICATION & INITIAL SETUP-----	4
EU38MIC, EU50MIC & EU100MIC SPECIFICATIONS -----	5
DIE SET UP AND INSTALLATION -----	7
HYDRAULIC DIE INST ALLATION -----	8
CRIMPING & CALIBRATION-----	9
ACCUSTOP™ COUPLING STOP SET UP -----	10
INITIAL SET UP AND MAINTENANCE-----	11
TROUBLESHOOTING -----	12
COMPONENT PARTS BREAKDOWN-----	13

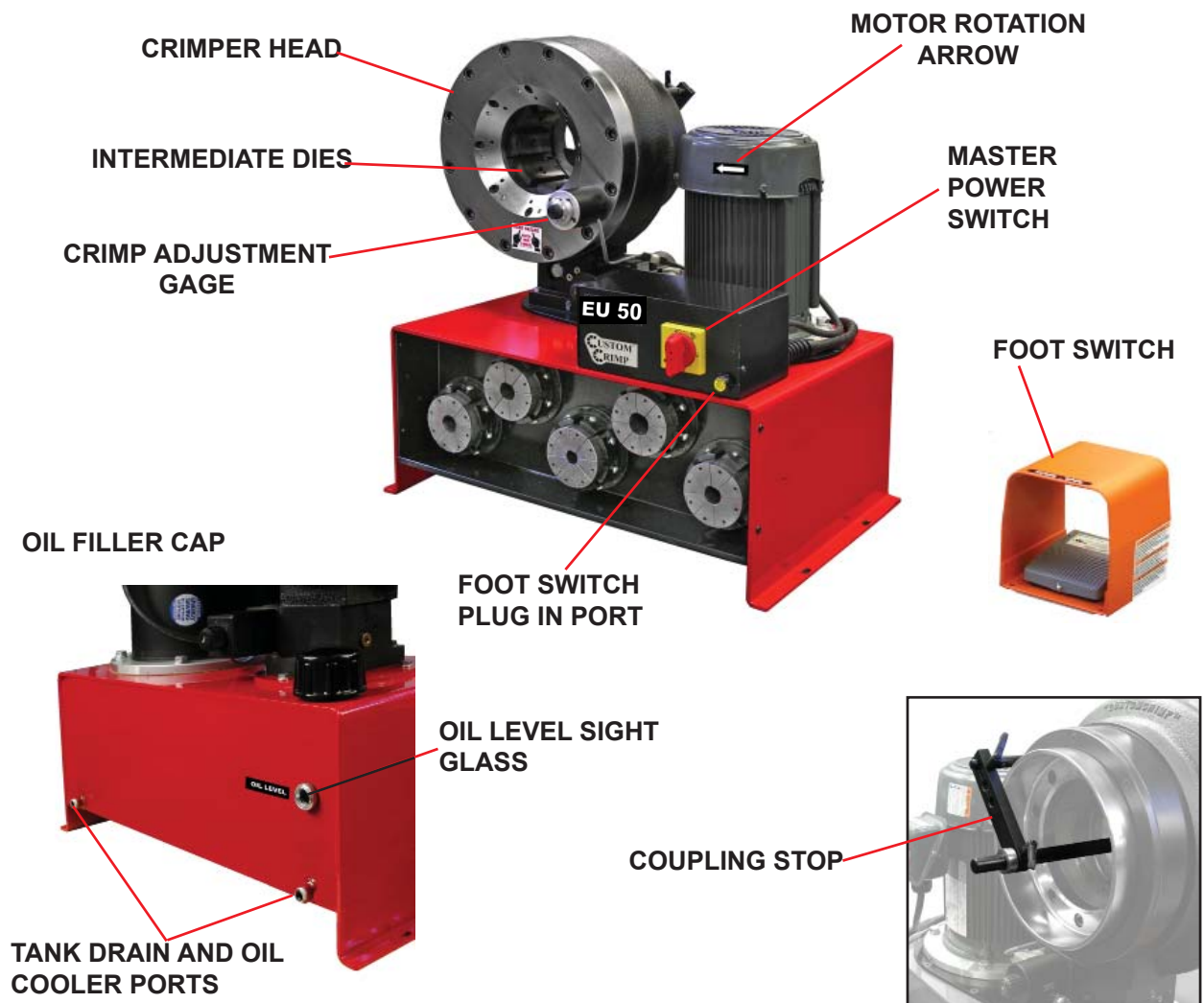

INITIAL CRIMPER SET UP

CHECK RESERVIOR OIL LEVEL WITH SIGHT GLASS AT REAR OF TANK

CHECK ELECTRICAL CIRCUIT TO BE CERTAIN THAT IT MATCHES THE CRIMPER REQUIREMENTS SHOWN ON THE TAG ATTACHED TO THE CRIMPER CORD.

MAKE CERTAIN THAT MOTOR ROTATES IN THE DIRECTION OF THE ARROW SHOWN ON THE MOTOR HOUSING.

IF MOTOR ROTATION IS INCORRECT REVERSE ANY TWO HOT WIRES IN THE CRIMPER PLUG. (NOTE: THIS IS APPLICABLE TO 3 PHASE CIRCUITS ONLY)

ALSO SEE INITIAL SETUP AND MAINTENANCE SECTION

EU SPECIFICATIONS:

MAX HEAD OPENING W/O DIES ----- 120mm (4.72in)
MASTER DIE INSIDE DIAMETER ----- 84mm(3.31in)
MAXIMUM DIE OPENING ----- DIE CLOSED DIAMETER + 38mm
CRIMPER SIZE ----- 29in LONG x 20in DEEP x 28in HIGH
WEIGHT -----474 LB (21.5 KG)
ELECTRICAL REQUIREMENTS ----- 3 PHASE (STANDARD)
MOTOR ----- 5.0 HP
RESERVOIR CAPACITY ----- 8 US GAL
OIL TYPE ----- ISO 46 HYDRAULIC OIL
ADAPTER DIES ----- 84S
HOSE CAPACITY ----- 2 INCH 4SP
----- 2in 2 WIRE

EU SPECIFICATIONS:

MAX HEAD OPENING W/O DIES ----- 160mm (6.30in)
MASTER DIE INSIDE DIAMETER ----- 130mm (5.11in)
MAXIMUM DIE OPENING ----- DIE CLOSED DIAMETER + 38mm
CRIMPER SIZE ----- 29in LONG x 20in DEEP x 32in HIGH
WEIGHT ----- 579 LB (262 KG)
ELECTRICAL REQUIREMENTS ----- 3 PHASE (STANDARD)
MOTOR ----- 5.0 HP
RESERVOIR CAPACITY ----- 8 US GAL
OIL TYPE ----- ISO 46 HYDRAULIC OIL
ADAPTER DIES ----- 99mm I.D. ADAPTER DIES INCLUDED
HOSE CAPACITY ----- 2½ in 6 WIRE
----- 2½ in INDUSTRIAL

EU SPECIFICATIONS:

MAX HEAD OPENING W/O DIES -----	182mm (7.17in)
MASTER DIE INSIDE DIAMETER -----	145mm(5.71in)
MAXIMUM DIE OPENING -----	DIE CLOSED DIAMETER + 60mm
CRIMPER SIZE -----	29in LONG x 20in DEEP x 32in HIGH
WEIGHT -----	579 LB (26.2 KG)
ELECTRICAL REQUIREMENTS -----	3 PHASE (STANDARD)
MOTOR -----	5.0 HP
RESERVOIR CAPACITY -----	8 US GAL
OIL TYPE -----	ISO 46 HYDRAULIC OIL
DIES -----	99mm I.D. ADAPTER DIES INCLUDED
HOSE CAPACITY -----	2in 6 WIRE
-----	4in INDUSTRIAL

- Dies are available for the EU38MIC crimper in 84S Series
- Dies are available for the EU50MIC crimper in 84S, 99S and 130S Series
- Dies are available for the EU100MIC crimper in 84S, 99S and 145S Series
- A set of 130mm O.D - 99mm I.D. Intermediate Dies is furnished with the EU50MIC crimper.
- A set of 145mm O.D - 99mm I.D. Intermediate Dies is furnished with the EU100MIC crimper.

The I.D. of the intermediate die must match the O.D. of the hydraulic die or accurate crimps are not possible.

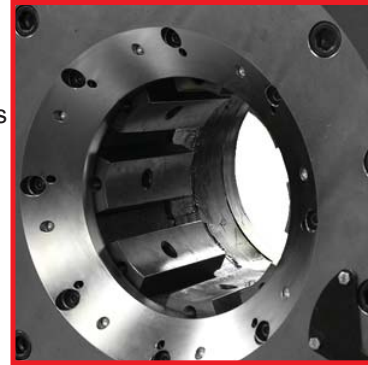

INDUSTRIAL DIE INSTALLATION (EU· 00· ..) · · INTERMEDIATE ADAPTER DIE INSTALLATION

Turn on the crimper at the master power switch and bring the master dies to the full open position or to the position where the die removal tool can be inserted to release the retaining spring.

Insert the die removal tool in the release hole to release the retaining spring and attach either an Intermediate Adapter Die or an Industrial Die to the Master Die. The numbers stamped on the face of the die should face the operator.

Note that on some crimpers the master dies must be slightly closed in order to completely insert the die removal tool.

Mount all 8 dies in a similar manner.

If Industrial Dies are being used, proceed to the Crimping Instructions and set up the crimper for the correct crimp diameter.

If Hydraulic Dies are being used, see Hydraulic Die Installation instructions.

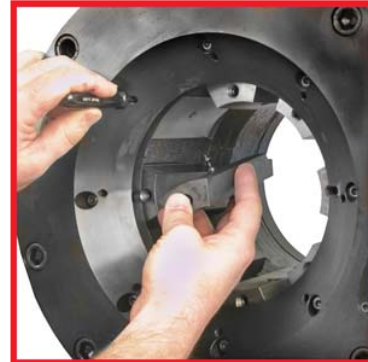

Install Intermediate Adapter Dies as shown previously making certain that the Intermediate Adapter Die I.D. matches the Hydraulic Die O.D.

Remove the Hydraulic Dies from their holder with the magnetic die insertion tool as shown.

The die size stamped on the face of the die should face toward the operator.

Align the studs of the Hydraulic Dies with the holes in the Adapter Dies and SLOWLY close the crimper head on the die set.

Bring the crimper head to a fully closed position and remove the die insertion tool.

The dies may also be inserted manually with the crimper head in the fully open position.

Proceed to the Crimping Instructions to set up the crimper for the hose and fitting being crimped.

For Hydraulic Die removal, bring the crimper head to the fully closed position. Insert the die removal tool and open the crimper head releasing the Hydraulic Dies from their spring retention holes.

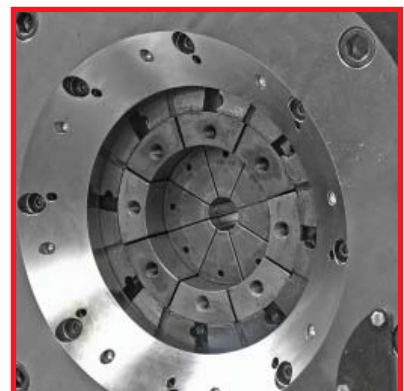
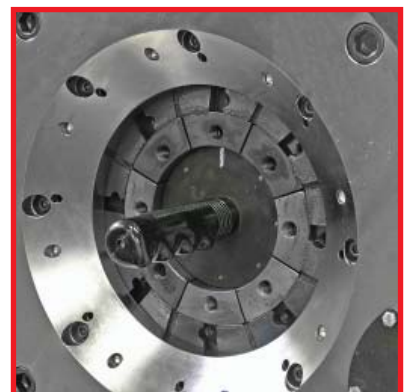

CRIMPING

Select the correct die for the combination of hose and fitting being crimped. Consult the hose and fitting manufacturer's specifications for the correct die to use and the final crimp diameter required.

The final crimp diameter will be the closed diameter stamped on the face of the die plus the number shown on the micrometer gage. See the micrometer setting example below:

Micrometer Setting Example

Each 100 on the micrometer dial represents 1 mm above the closed diameter of the die set. For example, with a 57mm die set installed and the micrometer set at 240 as shown in the photo, the final crimp diameter would be 59.4 mm (57mm + 2.4mm)



Insert the hose and fitting in the crimper head to the correct depth and press and hold the foot switch until the crimper shuts off. If the AccuStop™ coupling stop is being used make settings according to instructions.

Check the finished crimp diameter with calipers to be certain that it is within the hose manufacturer's specifications.



CALIBRATION

Due to physical variations in hose and fitting combinations, it may be necessary to offset the crimper in either the plus or minus direction by a few mm to get the measured crimp diameter to match the micrometer setting. If the final crimp dimension is consistently off in either direction the micrometer dial can be adjusted to compensate.

Make a crimp with the hose and fitting combination most commonly used, and measure the finished crimp diameter.

If necessary, loosen the set screw on the adjustment knob with a .050' hex key wrench.

Rotate the adjustment knob so that the number on the dial matches the actual diameter of the finished crimp.

Tighten the set screw and make another crimp to confirm that the crimper is set correctly.

Set Screw (.050 hex wrench)



The AccuStop™ coupling stop eliminates guesswork allowing the operator to visually observe exactly where the crimp will be positioned on the fitting without the need for trial and error and product scrap due to poor crimp positioning.

With the Coupling Stop retracted, load the appropriate set of dies and set crimp diameters as required.

Bring the dies to a fully closed position and follow the instructions below.

Coupling Stop Guide **Coupling Stop Clamp** **Coupling Stop**

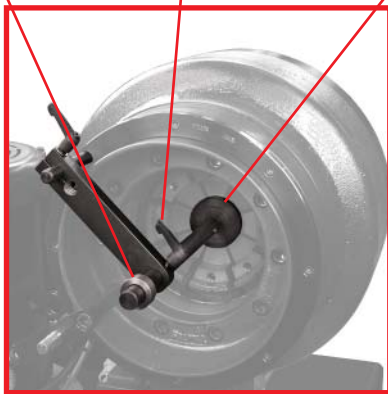

Part Identification



Loosen the Coupling Stop Clamp and position the Coupling Stop against the back face of the dies.



Slide the Coupling Stop Guide against the Coupling Stop Arm.

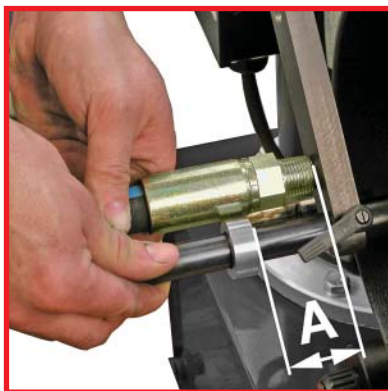

Hold the fitting against the Coupling Stop Arm withdraw the Coupling Stop Rod such that the Guide is aligned with the desired crimp position. Lock the Coupling Stop Clamp.



Position the fitting against the Coupling Stop and actuate the crimper in the normal manner.



The dimension from the face of the fitting to the crimp position will now be the dimension established in the previous step.

Initial Set Up

Do not lift the machine by the crimper head. Lift with a fork lift under the tank.

Mount the crimper on a sturdy surface.

Electrical Requirements: 3 Phase Current (Standard)

DO NOT RUN CRIMPER ON AN EXTENSION CORD.

Check to be certain that the motor rotates in the direction of the arrow shown on the motor housing. If motor rotation is opposite of the direction of the arrow and the electrical service is 3 phase, reverse any two hot wires in the electrical plug.

Damage to the pump can result if the motor does not rotate in the correct direction.

Check the oil level in the sight glass on the rear of the crimper. 8 U.S. gallons of ISO 46 hydraulic oil are required to completely refill the tank.

Oil can be drained from either of the two ports at the bottom of the tank.

An additional oil cooler, while not normally required, can be plumbed into the two ports at the rear of the crimper.



Maintenance

Front Flange Bolts: Periodically, every 6-12 months depending upon usage, the front flange bolt torque should be checked. The correct torque is 330NM (243 Ft Lbs).

Front Flange Bolts

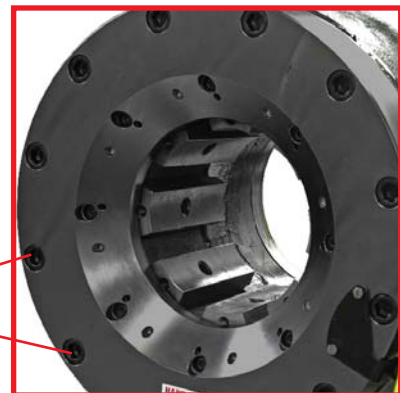

Lubricate the crimping head after each 100-500 crimping cycles or at the start of each shift if the crimper is used in a production setting.

- Bring the master dies to the fully closed position and lubricate the die fingers through the 8 lubrication fittings in the front flange face.
- Bring the dies to the fully open position and lubricate all 8 fittings again.

Use only a high quality moly-disulfide grease. Failure to do so may result in damage to the wearing surfaces.



PROBLEM: CRIMPER RUNS BUT IS SLOW OR NON-FUNCTIONAL

- Check supply voltage to see that it matches the voltage specified on the tag attached to the crimper.
- If the crimper is connected to a three phase circuit, check all three legs of the circuit to be certain that all legs are hot.
- Measure the voltage to the crimper when the crimper is under load. Voltage should be a minimum of 90% of line voltage when the crimper is under load.
Many performance problems are the result of low voltage or inadequate electrical service.
- Check motor rotation and be certain that the motor rotates in the direction of the arrow on the motor housing. For three phase units rotation can be reversed by switching any two wires in the plug.
- The circuit in the crimper is protected by a thermal overload relay. If the relay trips after resetting it from the master power switch, call for technical service.

PROBLEM: MOTOR RUNS BUT FOOT SWITCH WILL NOT OPERATE

- Power to the secondary circuit is supplied from a 24 volt step down transformer. If the motor runs normally but the foot switch will not function check the 2 amp slo blow fuse located in the control box as shown in the photo below.

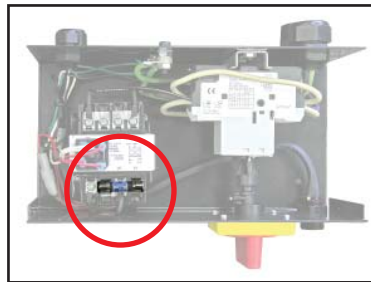
**PROBLEM: CRIMPER WILL CLOSE ON FITTING BUT DOES NOT DEVELOP POWER TO COMPLETE THE CRIMP**

- Fitting is too large for selected crimp die. Select a crimp die that is closer to final crimp diameter. Machine has built-in safety bypass to protect internal components from damage due to incorrect die selection.
- Check oil level. Position dies to the fully open position and check oil sight gauge in rear of machine. Be sure the oil level is in the middle of the sight glass. Use ISO 32 or 46 weight hydraulic oil.

If problem(s) persist contact Customer Service for additional troubleshooting assistance

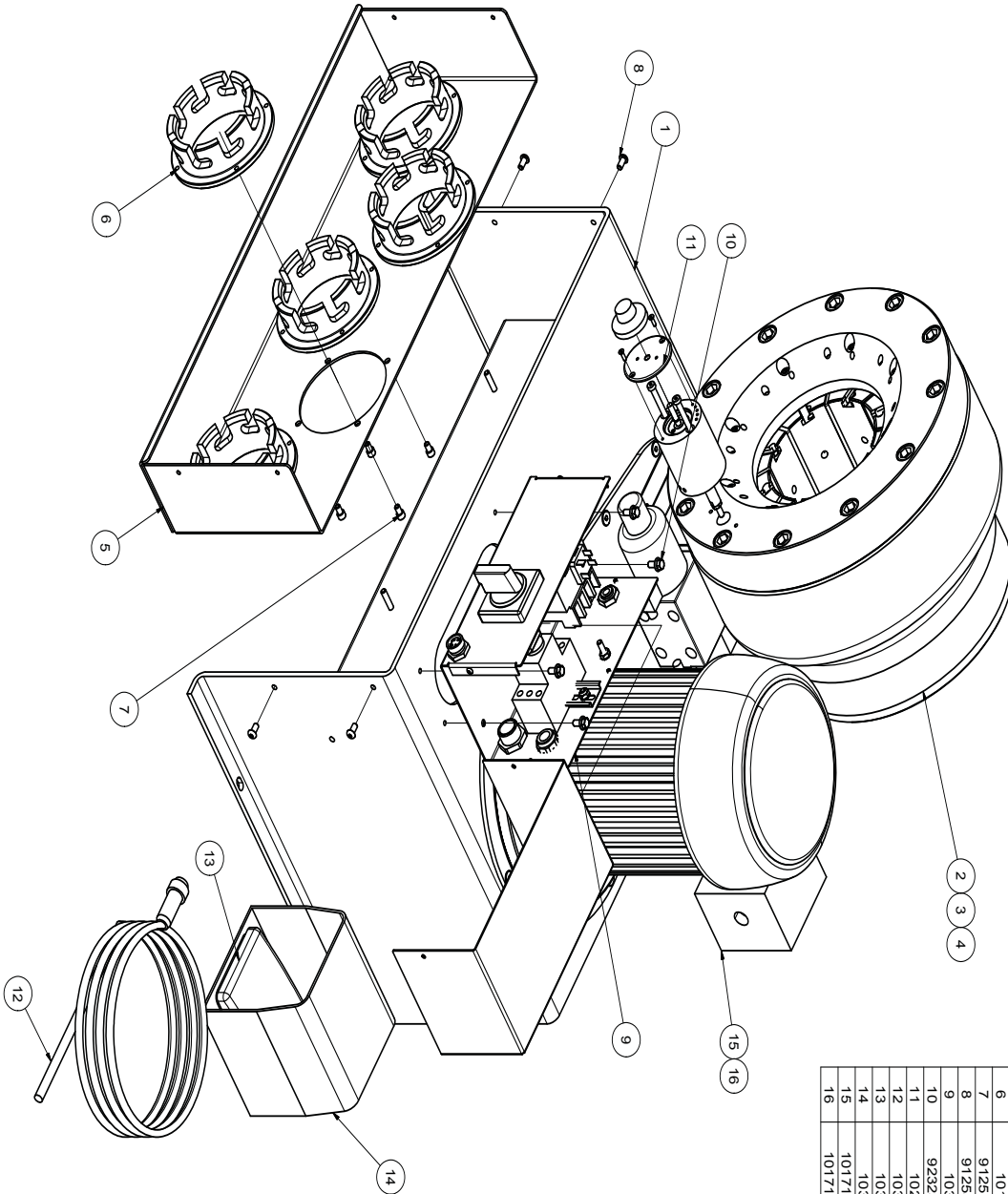

ITEM	PART NUMBER	DESCRIPTION	QTY
EU38/60/100MIC Assembly / (103052)			
1	102618-WELD	CC Chmper Reservoir	1
2	102800	CC-60 Head Assembly	1
3	102513	CC-450 Head Assembly	1
4	102594	CC-38 Head Assembly	1
5	102946	Front Die Panel	5
6	101242	99MM Die Holder	5
7	101243	94MM Die Holder	5
8	91261AS35	1/4-20 x 3/8" SHCS	20
9	91256AS37	1/4-20 x 1/2" BHCS	4
10	103053	Electrical Box Assembly	1
11	92323A512	1/4-20 X 1/2 SHF CS	4
12	102941	Dial Micrometer Assembly	1
13	103061	4 Pin Plug/12 Foot Cord	1
14	103058	Foot Switch	1
15	103054	Full Guard for Foot Switch	1
16	101714-5-8-3	5 HP/3 Ph/8cc Motor and Pump	1
16	101714-5-8-1	5 HP/1 Ph/8cc Motor and Pump	1

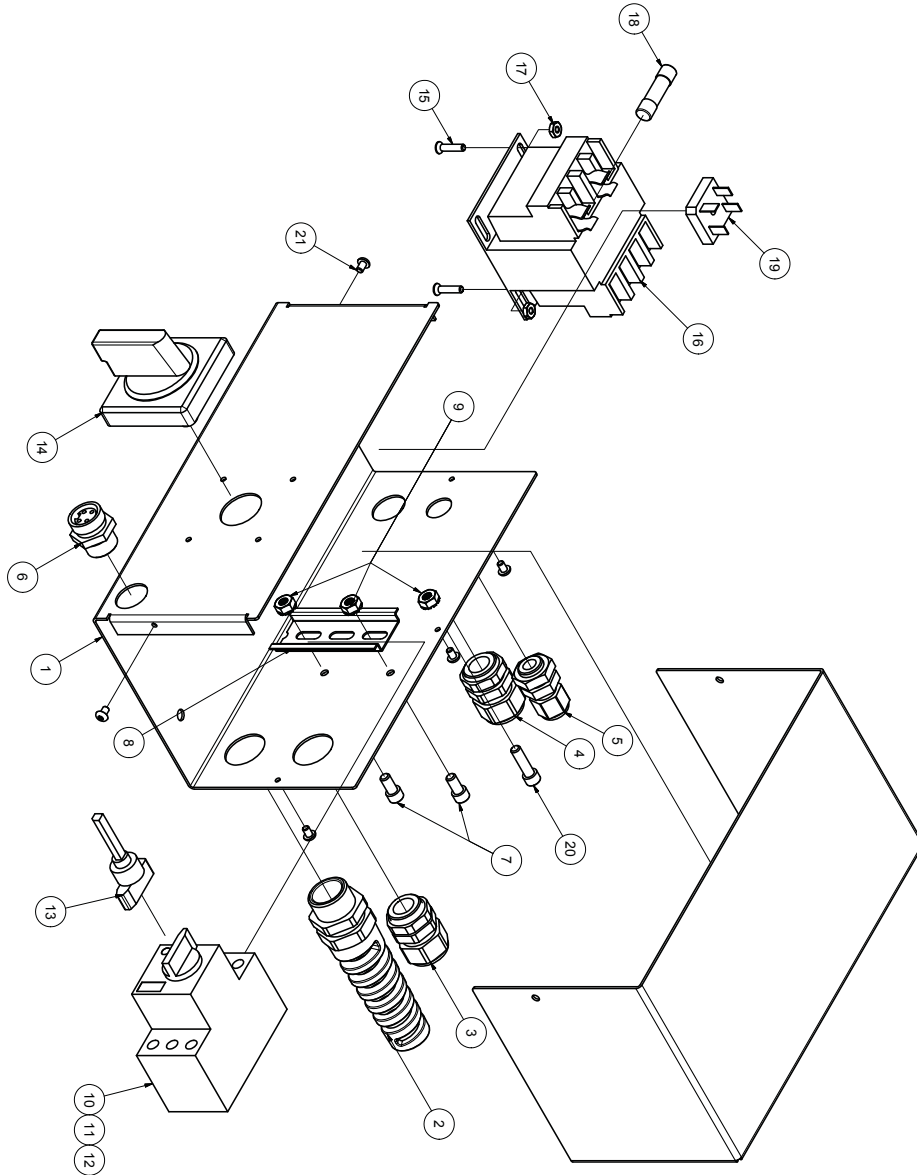

EU-38/50/100MIC Electrical Box (103053)					EU-38/50/100MIC Electrical Box (103053)				
ITEM	PART NUMBER	DESCRIPTION	STOCK NUMBER	QTY	ITEM	PART NUMBER	DESCRIPTION	STOCK NUMBER	QTY
1	102945	Electrical Box Metal Assembly	102945	1	12	1030574603	Manual Starter with Overload - 460V 3Ph	BM3RHB-004	1
2	68915K65	Cable Strain Relief	68915K65	1	13	103059-LINK1.35SL	Starter Switch Linkage	BZ0VYRL	1
3	68915K66	3/4 NPT Cord Grip	68915K66	1	14	103059	External Starter Handle and Linkage	BZ0VYRL	1
4	7807K64	Multi-Wire Cord Grip	7807K64	1	15	90273A197	#8-32 x 3/4 CS Screw	90273A197	2
5	68915K51	3/8 NPT Cord Grip	68915K51	1	16	103055	230/460-24VAC Transformer	PT500G	1
6	103060	4 Pin Receptical	18400A20A120	1	17	90480A009	#8-32 Nut	90480A009	2
7	91251A537	1/4-20 x 1/2 SHCS	91251A537	2	18	MEN2	Time-Delay 2 Amp Fuse	MEN2	1
8	3.125LDIN	3.125 Length DIN Rail	3.125LDIN	1	19	103056	Bridge Rectifier	MF1505	1
9	90675A029	1/4-20 Nut with Tooth Washer	90675A029	3	20	91251A541	1/4-20 X 7/8" SHCS	91251A541	1
10	103057-2303	Manual Starter with Overload - 230V 3Ph	BM3RHB-016	1	21	91255A190	#8-32 x 1/4 BHCS	91255A190	5
11	103057-2301	Manual Starter with Overload - 230V 1Ph	BM3RHB-032	1					

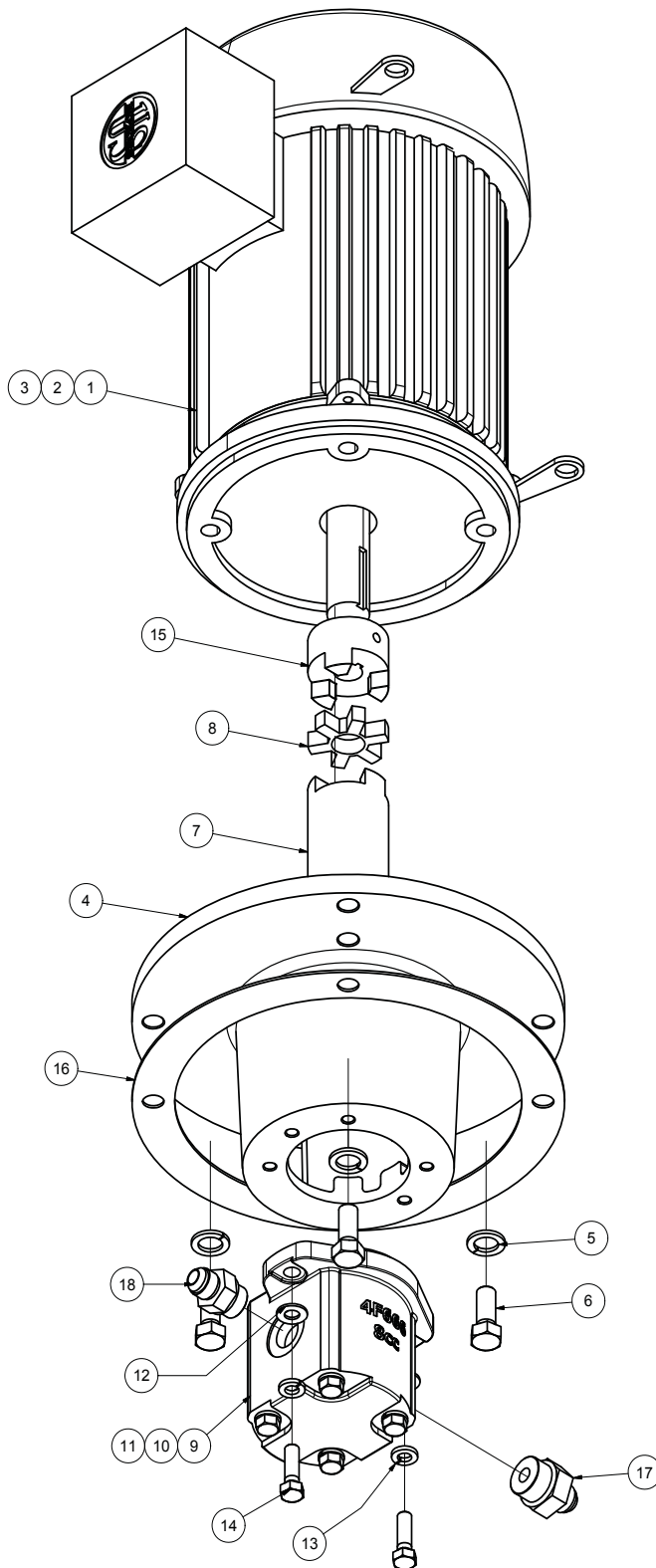

EU Motor and Pump Assembly (101714)			
ITEM	PART NUMBER	DESCRIPTION	QTY
1	101541	5 HP 1800 RPM Motor	1
2	101540	7.5 HP 1800 RPM Motor	1
3	102994	10 HP 1800 RPM Motor	1
4	101539	Motor Mounting Flange	1
5	91101A033	1/2 Lock Washer	4
6	92865A714	1/2-13 x 1 1/4" Bolt	4
7	101543-01	Motor Coupling	1
8	101543-03	Coupling Spider Insert	1
9	101713	8cc Gear Pump	1
10	101542	11cc Gear Pump	1
11	102992	14cc Gear Pump	1
12	98023A31	3/8 Washer	2
13	91102A031	3/8 Lock Washer	2
14	92865A626	3/8-16 x 1 1/4" Bolt	2
15	101543-02	3/4" Shaft Coupling	1
16	101539-01	Flange Gasket	1
17	6400-8-12	8 JIC 37 M to 12 SAE Adapter	1
18	6400-8-10	8 JIC 37 M to 10 SAE Adapter	1

FINAL ASSEMBLY PART NUMBER CREATION:
 101714-"MOTOR HP"-"PUMP SIZE"-"PHASE (IF REQ'D)"
 EX. 7.5 HP MOTOR WITH 11cc PUMP: 101714-7.5-11
 EX. 5 HP MOTOR WITH 8cc PUMP, SINGLE PHASE: 101714-5-8-1